



# Product Catalog

## **Packaged Rooftop Air Conditioners Voyager™ Light Commercial – Cooling, Gas/Electric & Heat Pump 15 to 25 Tons, 50 Hz**





# Introduction

## Packaged Rooftop Air Conditioners

Through the years, Trane has designed and developed the most complete line of Packaged Rooftop products available in the market today. Trane was the first to introduce the Micro—microelectronic unit controls—and has continued to improve and revolutionize this design concept.

The ReliaTel™ control platform offers the same great features and functionality as the original Micro, with additional benefits for greater application flexibility.

Voyager™ continues to provide the highest standards in quality and reliability, comfort, ease of service, and the performance of Trane light commercial products.

Trane customers demand products that provide exceptional reliability, meet stringent performance requirements, and are competitively priced. Trane delivers with Voyager.

Voyager features cutting edge technologies: reliable compressors, Trane engineered ReliaTel controls, computer-aided run testing, and Integrated Comfort™ Systems. So, whether you're the contractor, the engineer, or the owner you can be certain Voyager Products are built to meet your needs.

## Copyright

This document and the information in it are the property of Trane, and may not be used or reproduced in whole or in part without written permission. Trane reserves the right to revise this publication at any time, and to make changes to its content without obligation to notify any person of such revision or change.

## Trademarks

All trademarks referenced in this document are the trademarks of their respective owners.

## Revision Summary

Updated Features & Benefits, General Data, Electrical Data, Dimensional Data, and Weight, sections.



# Table of Contents

Features and Benefits .....	4
Standard Features .....	6
Variety of Options .....	9
Other Benefits .....	12
Application Considerations .....	15
Selection Procedure (SI/IP) .....	16
SI Selection Procedure .....	16
IP Selection Procedure .....	19
Model Number Descriptions .....	22
General Data .....	24
Performance Data .....	30
Controls .....	59
ReliaTel Controlled Units .....	59
Electrical Data .....	62
Jobsite Connections .....	66
Dimensional Data .....	67
Weights .....	73
Mechanical Specifications .....	79
Factory Installed Options .....	81
Factory or Field Installed Options .....	82
Field Installed Options .....	83



# Features and Benefits

**Table 1. Voyager™ Light Commercial 50Hz control options – standard and optional**

	Standard Features	Options <sup>(a)</sup>		
		Factory Installed	Factory or Field Installed	Field Installed
Discharge Line Thermostat	X			
LonTalk® Communications Interface (LCI)			X	
ReliaTel™ Microprocessor Controls	X			
ReliaTel™ Options Module			X	
Thermostat				X
Trane® Communications Interface (TCI)			X	
Zone Sensors and Remote Zone Sensors				X

(a) Refer to model number description for option availability

**Table 2. Voyager™ Light Commercial 50Hz features - standard and optional**

	Standard Features	Options <sup>(a)</sup>		
		Factory Installed	Factory or Field Installed	Field Installed
2" MERV 8 Filters or 2" MERV 13 Filters with Filter Removal Tool		X		
2" throwaway filters	X			
Anti-Short Cycle Timer	X			
Barometric Relief				X
Belt Drive Motors	X			
Clogged Filter/Fan Failure Switch			X	
CO <sub>2</sub> Sensor				X
CO <sub>2</sub> Sensor Wiring (Wiring Only)		X		
Colored and Numbered Wiring	X			
Complete Coat™ Microchannel Condenser Coil <sup>(b)</sup>		X		
Condensate Overflow Switch		X		
Crankcase Heaters	X			
Dedicated Airflow	X			
Digital Display Zone Sensor				X
Discharge Air Temperature Sensing Kit			X	
Easy Access Low Voltage Terminal Board (LTB)	X			
Economizer - Standard, Downflow			X	
Economizer - Standard, Horizontal				X
Electric Heaters			X	
Foil-Faced and Edge Captured Insulation	X			
Frostat™			X	
High and Low Static Drive Kits				X
High Efficiency Drum and Tube Heat Exchanger	X			
High Efficiency Gas Heat with Hot Surface Ignition	X			
High Pressure Cutout	X			
Hinged Access Doors		X		
IAQ Sloped Condensate Drain Pan	X			

**Table 2. Voyager™ Light Commercial 50Hz features - standard and optional**

	Standard Features	Options <sup>(a)</sup>		
		Factory Installed	Factory or Field Installed	Field Installed
Liquid Line Refrigerant Drier	X			
Low Ambient Cooling to 0°F	X			
LP Conversion Kit				X
Manual Outside Air Dampers				X
Microchannel Type Condenser Coils <sup>(b)</sup>	X			
Motorized Outside Air Dampers				X
Operating Charge of R-410A	X			
Oversized Motors				X
Phase Monitor	X			
Provisions for Through-the-Base Gas Connections	X			
Quick Access Panels	X			
Quick Adjust Idler Arm Pulley	X			
Reference or Comparative Enthalpy				X
Remote Potentiometer				X
Roof Curb (Downflow Only)				X
Single Point Power	X			
Single Side Service	X			
Stainless Steel Drain Pan		X		
Stainless Steel Heat Exchanger with 10 Year Warranty				
Standardized Components	X			
Through the Base Electrical Access		X		
Through the Base Electrical with Circuit Breaker		X		
Through the Base Electrical with Disconnect Switch		X		
Tool-less Hail Guards				X
U-shaped Airflow Pattern	X			
Ventilation Override Accessory				X

(a) Refer to model number description for option availability.

(b) T and Y units only.

## Standard Features

### Anti-Short Cycle Timer (Standard with ReliaTel™)

Provides a 3 minute minimum “ON” time and 3 minute “OFF” time for compressors to enhance compressor reliability by assuring proper oil return.

### Colored And Numbered Wiring

Save time and money tracing wires and diagnosing the unit.

### Compressors



Voyager contains the best compressor technology available to achieve the highest possible performance.

Dual compressors are outstanding for humidity control, light load cooling conditions and system back-up applications. Dual compressors are available on all models.

### Condenser Coil

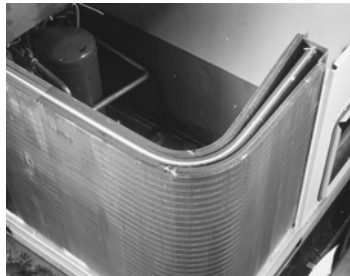

Voyager boasts a patent-pending 1+1+1 condenser coil, permanently gapped for easy cleaning.

**Note:** Used on Heat Pump units.

### Controls—ReliaTel

ReliaTel™ microprocessor controls provide unit control for heating, cooling and ventilating utilizing input from sensors that measure indoor and outdoor temperature and other zone sensors. ReliaTel also provides outputs for building automation systems and expanded diagnostics. For a complete list of ReliaTel offerings, refer to [“Other Benefits,” p. 12.](#)

### Conversionless Units

The dedicated design units (either downflow or horizontal) require no panel removal or alteration time to convert in the field—a major cost savings during installation. Horizontal units come complete with duct flanges so the contractor doesn’t have to field fabricate them. These duct flanges are a time and cost saver.

### Crankcase Heaters

These band heaters provide improved compressor reliability by warming the oil to prevent migration during off-cycles or low ambient conditions. These are standard on all Voyager models.

### Discharge Line Thermostat

A bi-metal element discharge line thermostats installed as a standard option on the discharge line of each system. This standard option provides extra protection to the compressors against high

discharge temperatures in case of loss of charge, extremely high ambient and other conditions which could drive the discharge temperature higher.

### Easy Access Low Voltage Terminal Board      Foil Faced Insulation



Voyager's Low Voltage Terminal Board is external to the electrical control cabinet. It is extremely easy to locate and attach the thermostat wire and test operation of all unit functions. This is another cost and time saving installation feature.



All panels in the evaporator section of the unit have cleanable foil-faced insulation. All edges are either captured or sealed to ensure no insulation fibers get into the airstream.

### Heat Exchanger—Drum and Tube

The cabinet (pictured right) features a drum and tube heat exchanger that is manufactured using aluminized steel with stainless steel components for maximum durability.

The requirement for cycle testing of heat exchangers is 10,000 cycles by ANSI Z21.47. This is the standard required by both UL and AGA for cycle test requirements.

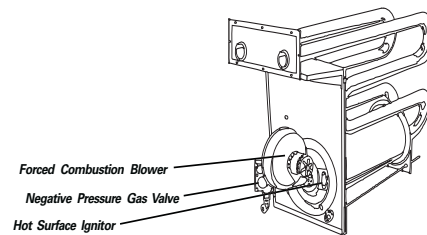

The drum and tube design has been tested and passed over 150,000 cycles, which is over 15 times the current ANSI cycling requirements. The negative pressure gas valve will not allow gas flow unless the combustion blower is operating. This is one of our unique safety features.

The forced combustion blower supplies pre-mixed fuel through a single stainless steel burner screen into a sealed drum where ignition takes place. It is more reliable to operate and maintain than a multiple burner system.

The hot surface ignitor is a gas ignition device which doubles as a safety device utilizing a continuous test to prove the flame. The design is cycle tested at the factory for quality and reliability. Our gas/electric rooftops exceed all California seasonal efficiency requirements and perform even better than the California NO<sub>x</sub> emission requirements.

### Low Ambient Cooling

All Voyager microprocessor units have cooling capabilities down to 0°F as standard.

### Low Voltage Connections

The wiring of the low voltage connections to the unit and the zone sensors is as simple as 1-1, 2-2, and 3-3. This simplified system makes it easy for the installer to wire.

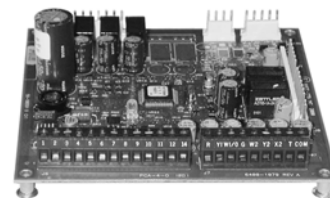

## Features and Benefits

---

### Microchannel Coils

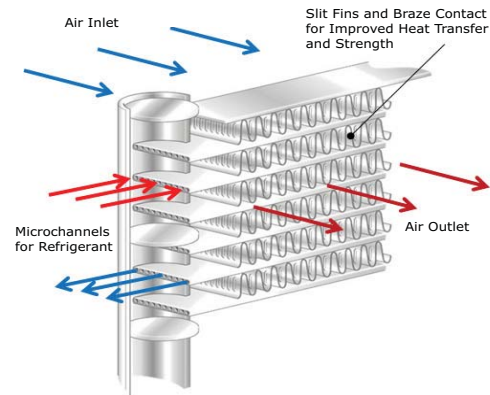

Microchannel coils are all-aluminum coils with fully-brazed construction. This design reduces risk of leaks and provides increased coil rigidity — making them more rugged on the jobsite. Their flat streamlined tubes with small ports and metallurgical tube-to-fin bond allow for exceptional heat transfer.

Microchannel all-aluminum construction provides several additional benefits:

- Light weight (simplifies coil handling)
- Easy to recycle
- Minimize galvanic corrosion

**Note:** Microchannel coils are used on Cooling and Gas/Electric units.

### Motors

All indoor fan motors are belt drive as standard.

### Pressure Cutouts

Low and high pressure cutouts are standard on all Voyager models.

### Phase Monitor

The Phase Monitor is a three-phase line monitor module that protects against phase loss, phase reversal and phase unbalance. It is intended to protect compressors from reverse rotation. It has an operating input voltage range of 190–600 Vac, and LED indicators for ON and FAULT. There are no field adjustments and the module will automatically reset from a fault condition.

### Quick-Access Panels

Remove three or more screws for access to the standardized internal components and wiring.

### Quick-Adjust Slider Plate

With the Quick-Adjust Slider Plate, the belt and sheaves can be quickly adjusted without moving the mounted fan motor. The result is a major savings in time and money.

### Single Point Power

A single electrical connection powers the unit.

### Single Side Service

Single side service is standard on all units.

### Sloped Drain Pans

Every Voyager unit has a non-corrosive, sloped drain pan made of pre-painted steel and standard on all units.

### Standardized Components

Components are placed in the same location on all Voyager units. Familiarize yourself with one Voyager and you are familiar with every Voyager.





Due to standardized components throughout the Voyager line, contractors/owners can stock fewer parts.

### **Through the Base Condensate**

Every unit includes provisions for through the base condensate drain connections. This allows the drain to be connected through the roof curb instead of a roof penetration.

## Variety of Options<sup>1</sup>

### Factory Installed Options

#### **Black Epoxy Pre-Coated Coils (W Units Only)**

The pre-coated coils are an economical option for protection in mildly corrosive environments.

#### **Circuit Breaker (Required with Through-the-Base Electrical)**

This option is a factory installed thermal magnetic, molded case, HACR Circuit Breaker with provisions for through the base electrical connections. Available on all models.

#### **CO<sub>2</sub> Sensor Wiring**

This is the unit wiring for field installed CO<sub>2</sub> sensors. Factory-installed CO<sub>2</sub> sensor wiring saves time and ensures proper unit connections for the field installed CO<sub>2</sub> sensor kits.

#### **Complete Coat™ Condenser Coil (T/Y Units Only)**

The cathodic epoxy type electrodisposition coating is formulated for high edge build to a number of different types of heat exchangers. The coating is selected to provide excellent resistance and durability to corrosive effects of alkalis, acids, alcohols, petroleum, seawater, salt air, and corrosive environments. This coating shall be available on microchannel condenser coils.

#### **Condensate Overflow Switch**

A condensate overflow switch is available to shut the unit down in the event that the condensate drain line becomes clogged. This option protects the unit from water overflowing from the drain pan and entering the base of the units.

#### **Disconnect Switch (Required with Through-the-Base Electrical)**

Factory installed three-pole, molded case, disconnect switch with provisions for through the base electrical connections are available. Available on all models.

Codes require a method of assured unit shutdown for servicing. Field-installed disconnects sometimes interfere with service access. Factory installation of unit disconnects reduces costs, assures proper mounting and provides the opportunity to upgrade to unit circuit breaker protection.



#### **High Efficiency Filtration**

Voyager units offer a variety of high efficiency filtration options. MERV 8 and MERV 13 filters provide additional filtration beyond the capabilities of typical 2" throwaway filters. Also, when MERV 8 or MERV 13 filters are ordered, units come equipped with a filter removal tool.

<sup>1</sup> Refer to Model Number Description for option availability.

## Features and Benefits

---

### Hinged Access Doors

These doors permit easy access to the filter, fan/heat, and compressor/control sections. They reduce the potential roof damage from screws or sharp access door corners.



### Stainless Steel Drain Pan

For excellent corrosion and oxidation resistance, the optional stainless steel drain pan provides a cleanable surface that complement other IAQ solutions such as high efficiency filtration (MERV 8 or 13), or demand control ventilation (CO<sub>2</sub>).

### Stainless Steel Heat Exchanger

The optional stainless steel heat exchanger is constructed of 304 stainless steel. It is resistant to corrosion and oxidation and easy to clean. The high strength to weight ratio allows for high ventilation rates with gas units. With this option, a 10-year stainless steel heat exchanger warranty is standard.

### Through-the-Base Electrical Utility Access

An electrical service entrance shall be provided allowing electrical access for both control and main power connections inside the curb and through the base of downflow units, and through the front of horizontal units. Option will allow for field installation of liquid-tight conduit and an external field installed disconnect switch.

Factory provided through the base openings simplify wiring and piping. Because these utility openings frequently minimize the number of roof penetrations, the integrity of roofing materials is enhanced.

## Factory or Field Installed Options<sup>1</sup>

### Clogged Filter/Fan Failure Switch

A dedicated differential pressure switch is available to achieve active fan failure indication and/or clogged filter indication.

These sensors allow a zone sensor service light or Integrated Comfort System to indicate a dirty filter or a fan that's not working. The field installation charges for these valuable feedback devices often eliminate them from consideration. Factory installation can make such features a good investment.

### Discharge Air Sensing Kit

Provides true discharge air sensing in heating models. The kit is functional only with the ReliaTel™ Options Module.

### Economizer - Downflow

Economizers are equipped with either dry bulb or reference or comparative enthalpy sensing. These economizers provide free cooling as the outdoor temperature and/or humidity decreases. Correctly installed, they offer a valuable energy savings.

### Electric Heaters

Electric heat modules are available within the basic unit. If ordering the Through the Base Electrical option with an Electrical Heater, the heater must be factory installed.

---

<sup>1</sup> Refer to Model Number Description for option availability.

**Frostat™**

This capillary bulb embedded in the face of the evaporator coil monitors coil temperature to prevent evaporator icing and protect the compressor. Recommended for applications with low leaving air temperatures, low airflow and or high latent load applications.

**LonTalk® Communications Interface**

The LonTalk communications interface allows the unit to communicate as a Tracer™ LCI-V device or directly with generic LonTalk Network Building Automation System Controls.

**Motors**

Factory or field installed oversized motors available for high static applications are available.

**Oversized Motors**

Factory or field installed oversized motors available for high static applications.

**Trane Communication Interface (TCI)**

Available factory or field installed. This module when applied with the ReliaTel™ easily interfaces with Trane's Integrated Comfort™ System.

**Field Installed Options<sup>1</sup>****Barometric Relief**

Designed to be used on downflow units, barometric relief is an unpowered means of relieving excess building pressure.

**CO<sub>2</sub> Sensor - Demand Control Ventilation (DCV)**

Demand-controlled ventilation (DCV) is a control strategy that responds to the actual demand (need) for ventilation by regulating the rate at which the HVAC system brings outdoor air into the building. A CO<sub>2</sub> sensor measures the concentration (parts per million, ppm) of CO<sub>2</sub> (Carbon Dioxide) in the air. As the CO<sub>2</sub> concentration changes, the outside air damper modulates to meet the current ventilation needs of the zone. The CO<sub>2</sub> sensor kit is available as a field installed accessory.

**Note:** Choose factory-installed CO<sub>2</sub> sensor wiring option to save time and ensure proper unit connections for the field installed CO<sub>2</sub> sensor kits.

**Dampers**

0–25 percent manual or 0–50 percent motorized outside air dampers are available.

**Digital Display Zone Sensor**

The Digital LCD (Liquid Crystal Display) zone sensor has the look and functionality of standard zone sensors. This sensor should be utilized with ReliaTel™ controls.

**Economizer - Horizontal**

Economizers are equipped with either dry bulb or reference or comparative enthalpy sensing. These economizers provide free cooling as the outdoor temperature and/or humidity decreases. Correctly installed, they offer a valuable energy savings.

**High Static Drive**

Available on many models, this high static drive accessory extends the capability of the standard motor. Avoid expensive motors and operating costs by installing this optimized sheave accessory.

---

<sup>1</sup> Refer to Model Number Description for option availability.

## Features and Benefits

---

### LP Conversion Kit

Provided for field conversion of gas/electric units from Natural gas to Propane.

### Remote Potentiometer

When properly installed in the economizer control circuitry, this accessory provides a remote variable resistance to enable the operator to adjust the minimum damper position.

### Roof Curbs

Available for downflow units. Only two roof curbs for the entire Voyager line simplifies curb selection.

### Tool-less Hail Guards

Tool-less, hail protection quality coil guards shall be field-installed for condenser coil protection. This option protects the condenser coil from vandalism and/or hail damage.



### Ventilation Override Accessory

With the Ventilation Override Accessory installed, the unit can be set to transition to up to three different pre-programmed sequences for Smoke Purge, Pressurization, and Exhaust. The transition occurs when a binary input on the RTOM is closed (shorted). This would typically be a hard wired relay output from a smoke detector or fire control panel.

### Zone Sensors/Thermostats

Available in programmable, automatic and manual styles.

## Other Benefits

### Airflow Distribution

Airflow is outstanding. The Voyager can replace an older machine with old ductwork and, in many cases, improve the comfort through better air distribution. The U-shaped airflow allows for improved static capabilities.

### Cabinet Integrity

For added water integrity, Voyager has a raised 1 1/8" lip around the supply and return of the downflow units to prevent water from blowing into the ductwork.

### Easy to Install, Service and Maintain

Because today's owners are very cost-conscious when it comes to service and maintenance, the Trane Voyager was designed with direct input from service contractors. This valuable information helped to design a product that would get the serviceman off the job quicker and save the owner money. Voyager does this by offering outstanding standard features enhanced by a variety of factory and field installed options, multiple control options, rigorously tested proven designs and superior product and technical support.

### **ReliaTel Controls Benefits**

ReliaTel™ controls provide unit control for heating, cooling and ventilating utilizing input from sensors that measure outdoor and indoor temperature.

#### ***ReliaTel Control Logic Enhances Quality and Reliability***

- prevents the unit from short cycling, considerably improving compressor life.
- ensures that the compressor will run for a specific amount of time which allows oil to return for better lubrication, enhancing the reliability of the compressor.

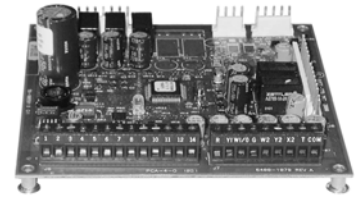

Voyager with ReliaTel™ reduces the number of components required to operate the unit, thereby reducing possibilities for component failure.

#### ***ReliaTel Makes Installing and Servicing Easy***

ReliaTel™ eliminates the need for field installed anti-shortcycle timer and time delay relays. ReliaTel™ controls provide these functions as an integral part of the unit. The contractor no longer has to purchase these controls as options and pay to install them. The wiring of the low voltage connections to the unit and the zone sensors is as easy as 1-1, 2-2, and 3-3. This simplified system makes wiring easier for the installer.

#### ***ReliaTel Makes Testing Easy***

ReliaTel™ requires no special tools to run the Voyager unit through its paces. Simply place a jumper between Test 1 and Test 2 terminals on the Low Voltage Terminal Board and the unit will walk through its operational steps automatically.

The unit automatically returns control to the zone sensor after stepping through the test mode a single time, even if the jumper is left on the unit.

As long as the unit has power and the “system on” LED is lit, ReliaTel is operational. The light indicates that the controls are functioning properly.

ReliaTel features expanded diagnostic capabilities when utilized with Trane Integrated Comfort™ Systems.

Some zone sensor options have central control panel lights which indicate the mode the unit is in and possible diagnostic information (dirty filters for example).

#### ***Other ReliaTel Benefits***

The ReliaTel™ built-in anti-shortcycle timer, time delay relay and minimum “on” time control functions are factory tested to assure proper operation.

ReliaTel softens electrical “spikes” by staging on fans, compressors and heaters.

Intelligent Fallback is a benefit to the building occupant. If a component goes astray, the unit will continue to operate at predetermined temperature setpoint.

Intelligent Anticipation is a standard ReliaTel feature. It functions continuously as ReliaTel and zone sensor(s) work together in harmony to provide much tighter comfort control than conventional electro-mechanical thermostats.

The same ReliaTel Board fits all Voyager Packaged Gas/Electrics, Cooling, and Heat Pump models. This provides standardization of parts for contractors. Less money is tied up in inventory with ReliaTel.

### **Rigorous Testing**

All of Voyager’s designs were rigorously rain tested at the factory to ensure water integrity. Actual shipping tests were performed to determine packaging requirements. Units were test shipped around the country to determine the best packaging. Factory shake and drop tests were used as

## Features and Benefits

---

part of the package design process to help assure that the unit arrives at the job site in top condition. Rigging tests include lifting a unit into the air and letting it drop one foot, assuring that the lifting lugs and rails hold up under stress.

The evaporator and condenser coils are leak tested at 225 psig and pressure tested to 450 psig. All parts are inspected at the point of final assembly. Sub-standard parts are identified and rejected immediately.

Every unit receives a 100 percent unit run test before leaving the production line to make sure it lives up to rigorous Trane requirements. Voyager units incorporate either a one piece top or the Trane-Tite-Top (T<sup>3</sup>). Each part of the top (either two or three pieces) overlaps in such a way that water cannot leak into the unit. These overlapped edges are gasketed and sealed to ensure superior water integrity.

### Unmatched Support

Trane Sales Representatives are a Support Group that can assist you with:

- Product
- Application
- Service
- Training
- Special Applications
- Specifications
- Computer Programs and much more

### VariTrac—Building Automation System

When Trane's changeover VAV System for light commercial applications is coupled with Voyager, it provides the latest in technological advances for comfort management systems and can allow thermostat control in every zone served by VariTrac.

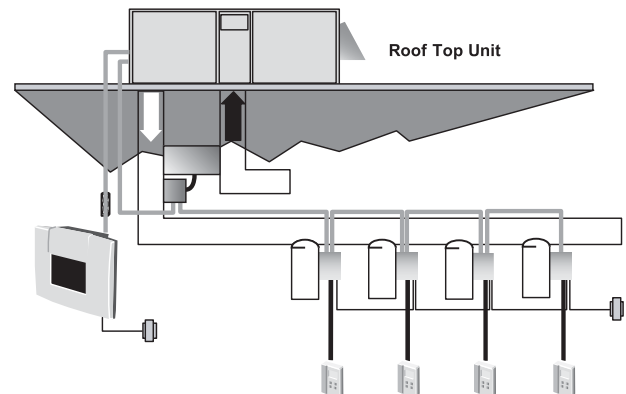

# Application Considerations

Application of this product should be within the cataloged airflow and cooling considerations.

## Barometric Relief

This product line offers an optional barometric relief damper for use in conjunction with economizer option. This accessory consists of gravity dampers which open with increased pressure. As the building air pressure increases, the pressure in the unit return air section also increases, opening the dampers and relieving the conditioned space.

### **Notes:**

- *The effectiveness of barometric relief damper during economizing operation is system related.*
- *Pressure drop of the return air system should be considered to control building pressurization.*

## Black Epoxy Coil

The coils are manufactured with a thermoset, vinyl coating that is bonded to the aluminum fin stock prior to the fin stamping process. These coils are an economical option for protection in mildly corrosive environments.

**Note:** *Not to be used where seacoast applications exist.*

## Clearance Requirements

The recommended clearances identified with unit dimensions should be maintained to ensure adequate serviceability, maximum capacity and peak operating efficiency. Actual clearances which appear inadequate should be reviewed with the local Trane sales personnel.

## Complete Coat™ Microchannel Condenser Coil

The cathodic epoxy type electrodisposition coating is formulated for high edge build to a number of different types of heat exchangers. The coating is selected to provide excellent resistance and durability to corrosive effects of alkalis, acids, alcohols, petroleum, seawater, salty air and other corrosive environments. This coating shall be available on microchannel condenser coils.

## Condensate Trap

The evaporator is a draw-thru configuration. A trap must be field provided prior to start-up on the cooling cycle.

## Heating Operation

The heat exchanger is manufactured with aluminized steel. To prevent condensation within the heat exchanger, do not exceed 50 percent outside air or a minimum mixed air temperature of 40°F.

## Optional Stainless Steel Heat Exchanger

The optional stainless steel heat exchanger is manufactured with 304 stainless steel. To prevent corrosion and prolong heat exchanger reliability, the minimum mixed air temperature allowed across the heat exchanger is 20°F.

## Low Ambient Cooling

The Voyager™ line features, with ReliaTel™ microprocessor controls, low ambient cooling down to 0°F. The following options need to be included/considered when low ambient applications are required: continuous fan operation, crankcase heaters (standard), thermal expansion valves, frostat.

Contact your local Trane Representative for more assistance with low ambient cooling applications.

## Unit Pitch

These units have sloped condensate drain pans. Units must be installed level. Any unit slope must be toward access side of the unit.



# Selection Procedure (SI/IP)

## SI Selection Procedure

### Cooling Capacity

**Note:** Cooling Capacity Procedure is the same for cooling (TS\*), gas/electric (YS\*) and heat pump (WS\*) units.

#### Step 1.

Calculate the building's total and sensible cooling loads at design conditions. Use the Trane calculation methods or any other standard accepted method.

Factors used in unit selection:

- Total Cooling Load: 40.0 kW
- Sensible Cooling Load: 29.0 kW
- Airflow: 8500 m<sup>3</sup>/h
- Electrical Characteristics:  
380-415/50/3
- Summer Design Conditions:
- Entering Evaporator Coil:  
27°C DB, 22°C WB,  
35°C Outdoor Ambient
- External Static Pressure: 127 Pa
- Rooftop—downflow configuration accessories
  - Roof Curb
  - Economizer
  - Electric Heat

#### Step 2.

Size the equipment using [Table 6, p. 30](#). Match the cooling loads at design conditions.

[Table 6, p. 30](#) shows that a TSD155F has a gross cooling capacity of 47.5 kW and 35.6 kW sensible capacity at 8500 m<sup>3</sup>/h and 35°C DB outdoor ambient with 27°C DB, 19°C WB air entering the evaporator.

#### To Find Capacity at Intermediate Conditions Not in the Table:

When the design conditions are between two numbers that are in the capacity table, interpolation is required to approximate the capacity.

**Note:** Extrapolation outside of the table conditions is not recommended.



### Step 3.

In order to select the correct unit which meets the building's requirements, the fan motor heat must be deducted from the gross cooling capacity. The amount of heat that the fan motor generates is dependent on the effort by the motor, airflow and static pressure. To determine the total unit static pressure (see [Table 50, p. 56](#) for Static Pressure Drops Through Accessories):

External Static Duct System	127 Pa
Standard Filter 25mm	19 Pa
Economizer (100% OA)	12 Pa
Electric Heater Size 27 kW	11Pa
Total Static Pressure	169 Pa

**Notes:**

1. Reference "Heating Capacity" section on this page for determination of heater size.
2. No additional static add for gas/heat exchanger.

**Note:** The Evaporator Fan Performance (see [Table 22, p. 44](#)) has already accounted for the pressure drop for standard filters and wet coils (see note below [Table 22, p. 44](#)). Therefore, the actual total static pressure is 169 - 19 (from [Table 50, p. 56](#)) = 150 Pa.

With 8500 m<sup>3</sup>/h and 150 Pa, [Table 22, p. 44](#) shows 1.12 kW for this unit. The formula below can be used to calculate Fan Motor Heat:

$$\begin{aligned} \text{Fan Motor Heat} &= 1.23 * \text{Fan Power (kW)} \\ 1.23 * 1.12 \text{ kW} &= 1.3776 \text{ kW} \end{aligned}$$

Now subtract the fan motor heat from the gross cooling capacity of the unit:

$$\begin{aligned} \text{Net Total Cooling Capacity} &= \\ 47.5 - 1.37 &= 46.12 \end{aligned}$$

$$\begin{aligned} \text{Net Sensible Cooling Capacity} &= \\ 35.6 - 1.37 &= 34.22 \end{aligned}$$

### Step 4.

If the performance will not meet the required load of the building, total or sensible cooling load, try a selection at the next higher size unit.

## Heating Capacity

**Note:** Heating capacity procedures DIFFER for cooling (TS\*), gas/electric (YS\*) and heat pump (WS\*) units.

### Step 1.

Calculate the building heating load using the Trane calculation form or other standard accepted method.

### Step 2.

Size the system heating capacity to match the calculated building heating load. The following are building heating requirements:

#### TS\* cooling units:

- 380 volt/three-phase Power Supply
- Total heating load of 20.5 kW
- Airflow of 8500 m<sup>3</sup>/h

The electric heat accessory capacities are listed in [Table 54, p. 62](#). From the table, a 26.9 kW heater at 415 volts is selected. In order to determine capacity at 380 volts, the heater voltage correction

## Selection Procedure (SI/IP)

---

factor from [Table 55, p. 62](#) must be used. Therefore,  $26.9 \text{ kW} \times 0.84$  (voltage correction factor) = 22.59 kW.

### **YS\* gas/electric:**

The fuel used is natural gas with a total heating load of 30 kW. [Table 4, p. 26](#) shows 61.1 kW and 85.5 kW input models. The output capacities of these furnaces are 49.6 kW and 69.4 kW, respectively. The low heat model with 49.6 kW output best matches the building requirements.

### **WS\* heat pumps:**

Total heating load of 30.0 kW. Outdoor ambient (Winter) of -9°C DB and indoor return of 21°C DB and an airflow of 8500 m<sup>3</sup>/h. The unit is using a 380 V power supply. Use the integrated portion of [Table 18, p. 42](#) for the WC\*155 to determine capacity at winter design conditions. The mechanical heating portion of the heat pump will provide 20.9 kW.

### **Step 3.**

**Note:** This step does not apply to TS\* and YS\* units.

### **WS\* heat pumps:**

Because 22.1 kW is less than the building's required heating capacity at winter design condition, a supplementary heater must be selected.

$$30.0 - 20.9 = 9.1 \text{ kW}$$

From [Table 63, p. 64](#), a 13.4 kW heater at 415 V is selected. To find the capacity at 380 V, the heater voltage correction factor from [Table 64, p. 64](#) must be used. Therefore,  $13.4 \text{ kW} \times 0.84$  (voltage correction factor) = 11.26 kW. This heater will be adequate to do the job.

## Air Delivery Selection

**Note:** Air Deliver procedures is the same for cooling (TS\*), gas/electric (YS\*) and heat pump (WS\*) units.

External static pressure drop through the air distribution system has been calculated to be 150 Pa. From [Table 50, p. 56](#), static pressure drop through the economizer is 12 Pa and the 27 kW heater is 12 Pa (127 + 12 + 12). Enter ([Table 22, p. 44](#)) for a TSD155F at 8500 m<sup>3</sup>/h and 150 Pa static pressure.

The standard motor at 566 rpm will give the desired airflow at a rated kW of 1.12.

## IP Selection Procedure

### Cooling Capacity

**Note:** *Cooling Capacity Procedure is the same for cooling (TS\*), gas/electric (YS\*) and heat pump (WS\*) units.*

#### Step 1.

Calculate the building's total and sensible cooling loads at design conditions. Use the Trane calculation methods or any other standard accepted method.

Factors used in unit selection:

- Total Cooling Load: 140 MBh
- Sensible Cooling Load: 100 MBh
- Airflow: 5000 cfm
- Electrical Characteristics:  
380-415/50/3
- Summer Design conditions:
- Entering Evaporator Coil:  
80 DB, 73 WB
- Outdoor Ambient: 95 DB
- External Static pressure:  
0.50 in. wg
- Rooftop - downflow configuration
- Accessories
  - Roof Curb
  - Economizer
  - Electric Heat

#### Step 2.

As a starting point, a rough determination must be made of the size of the unit. The final selection will be made after examining the performance at the given conditions. Divide the total cooling load by nominal Btu/h per ton (12 MBh per ton); then round up to the nearest unit size.

$$140 \text{ MBh} / 12 \text{ MBh} = 11.6 \text{ tons}$$

#### Step 3.

[Table 7, p. 31](#) shows that a TSD155F has a gross cooling capacity of 162.2 MBh and 121.4 MBh sensible capacity at 5000 cfm and 95 DB outdoor ambient with 80 DB, 73 WB air entering the evaporator.

#### To Find Capacity at Intermediate Conditions Not in the Table:

When the design conditions are between two numbers that are in the capacity table, interpolation is required to approximate the capacity.

**Note:** *Extrapolation outside of the table conditions is not recommended.*

## Selection Procedure (SI/IP)

---

### Step 4.

In order to select the correct unit which meets the building's requirements, the fan motor heat must be deducted from the gross cooling capacity. The amount of heat that the fan motor generates is dependent on the effort by the motor, cfm and static pressure. To determine the total unit static pressure you add the external static pressure to the additional static related by the added features (see [Table 51, p. 57](#) for Static Pressure Drops Through Accessories):

External Static Duct System	0.50 wg
Standard Filter 1in.	0.08 wg
Economizer (100% OA)	0.05 wg
Electric Heater Size 27 kW	0.05 wg
Total Static Pressure	0.68 wg

**Notes:**

1. Reference "Heating Capacity" section on this page for determination of heater size.
2. No additional static add for gas/heat exchanger.

**Note:** The Evaporator Fan Performance [Table 23, p. 44](#) has already accounted for the pressure drop for standard filters and wet coils (see note below [Table 23, p. 44](#)). Therefore, the actual total static pressure is  $0.68 - 0.08$  (from [Table 51, p. 57](#)) =  $0.60$  wg.

With 5000 cfm and 0.60 wg, [Table 23, p. 44](#) shows 1.50 bhp for this unit. The formula below can be used to calculate Fan Motor Heat:

$$\text{Fan Motor Heat} = 3.15 * \text{Fan bhp}$$

$$3.15 * 1.50 = 4.725 \text{ MBh}$$

Now subtract the fan motor heat from the gross cooling capacity of the unit:

$$\text{Net Total Cooling Capacity} =$$

$$162.2 - 4.725 = 157.475 \text{ MBh}$$

$$\text{Net Sensible Cooling Capacity} =$$

$$121.4 - 4.725 = 116.675 \text{ MBh}$$

### Step 5.

If the performance will not meet the required load of the building, total or sensible cooling load, try a selection at the next higher size unit.

## Heating Capacity

**Note:** Heating capacity procedures DIFFER for cooling (TS\*), gas/electric (YS\*) and heat pump (WS\*) units.

### Step 1.

Calculate the building heating load using the Trane calculation form or other standard accepted method.

### Step 2.

Size the system heating capacity to match the calculated building heating load. The following are building heating requirements:

#### TS\* cooling units:

380 volt/3 phase Power Supply

Total heating load of 75.0 MBh

5000 cfm

The electric heat accessory capacities are listed in [Table 54, p. 62](#). From the table, a 26.9 kW heater will deliver 91.73 MBh at 415 volts. In order to determine capacity at 380 volts, the heater voltage correction factor from [Table 55, p. 62](#) must be used. Therefore, 91.73 MBh x 0.84 (voltage correction factor) = 77.05 MBh.

#### YS\* gas/electric:

Fuel natural gas and a total heating load of 115 MBh. [Table 4, p. 26](#) shows 208.3 MBh and 291.7 MBh input models. The output capacities of these furnaces are 169.2 MBh and 236.7 MBh respectively. The low heat model with 169.2 MBh output best matches the building requirements.

#### WS\* heat pumps:

Total heating load of 100 MBh. Outdoor ambient (Winter) of 17 DB and Indoor Return of 70 DB and an airflow of 5000 cfm. The unit is using a 380 V power supply. Use the integrated portion of [Table 19, p. 42](#) for the WC\*155 to determine capacity at winter design conditions. The mechanical heating portion of the heat pump will provide 71.2 MBh.

### Step 3.

**Note:** This step does not apply to TS\* and YS\* units.

#### WS\* heat pumps:

Because 71.2 MBh is less than the building's required heating capacity at winter design conditions, a supplementary heater must be selected.

100 MBh - 71.2 MBh = 28.8 MBh

From [Table 63, p. 64](#), a 13.4 kW heater at 415 V is selected. To find the capacity at 380 V, the heater voltage correction factor from [Table 64, p. 64](#) must be used. Therefore, 13.4 kW x 0.84 (voltage correction factor) = 11.26 kW. This heater will be adequate to do the job. 38.3 MBh.

## Air Delivery Selection

**Note:** Air Delivery procedures is the same for cooling (TS\*), gas/electric (YS\*) and heat pump (WS\*) units.

External static pressure drop through the air distribution system has been calculated to be 0.60 inches of water. From [Table 51, p. 57](#), static pressure drop through the economizer is 0.05 and the 26.9 kW heater is 0.05 inches of water (0.50 + 0.05 + 0.05). Enter ([Table 23, p. 44](#)) for a TSD155 at 5000 cfm and 0.60 static pressure. The standard motor at 566 rpm will give the desired airflow at a rated bhp of 1.50.



# Model Number Descriptions

T	S	D	1	5	5	F	D	R	O	A	A			
1	2	3	4	5	6	7	8	9	10	11	12			
<b>Digit 1 – Unit Type</b>			<b>Digit 15 – Supply Fan/Drive Type/Motor</b>						<b>Digit 21 – Communications Options</b>					
T = Packaged Cooling, Electric Heat			0 = Standard Motor						0 = Without Communications Options					
Y = Packaged Cooling, Gas Heat			1 = Oversized Motor						1 = Trane Communications Interface <sup>4, 13</sup>					
W = Packaged Heat Pump, Electric Heat			3 = High Efficiency Motor						2 = Lontalk Communications Interface <sup>4</sup>					
<b>Digit 2 – Efficiency</b>			6 = Single Zone Variable Air Volume Standard Motor						6 = Building Automation Control Network Communications Interface					
S = Standard			7 = Multi-Speed Standard Motor						<b>Digit 22 – Refrigeration System Option</b>					
<b>Digit 3 – Airflow Configuration</b>			8 = Single Zone Variable Air Volume Oversized Motor						0 = Standard refrigeration system					
D = Downflow			9 = Multi-Speed Oversized Motor						<b>Digit 23 – Refrigeration Controls</b>					
H = Horizontal			A = Single Zone Variable Air Volume Standard Motor w/ Shaft Ground Ring						0 = Without Refrigeration Controls					
<b>Digit 4, 5, 6 – Nominal Gross Cooling Capacity (MBh)</b>			B = Multi-Speed Standard Motor w/ Shaft Ground Ring						1 = Frostat					
155 = 15 Tons Standard Efficiency			C = Single Zone Variable Air Volume Oversized Motor w/ Shaft Ground Ring						<b>Digit 24 – Smoke Detector</b>					
175 = 17½ Tons Standard Efficiency			D = Multi-Speed Oversized Motor w/ Shaft Ground Ring						0 = Without Smoke Detector					
200 = 20 Tons Standard Efficiency			<b>Digit 7 – Major Design Sequence</b>			<b>Digit 16 – Hinged Service Access / Filters</b>						A = Return Air Smoke Detector		
250 = 25 Tons Standard Efficiency			E = Round Tube Plate Fin Type Condenser Coils			0 = Standard Panels/Standard Filters						B = Supply Air Smoke Detector		
<b>Digit 8 – Voltage Selection</b>			F = Microchannel Type Condenser Coils			<b>Digit 17 – Condenser Coil Protection</b>						C = Return/Supply Air Smoke Detector		
D = 380-415/50/3			<b>Digit 9 – Unit Controls</b>			0 = Standard Coil						D = Plenum Smoke Detector		
T = 200/50/3 <sup>11</sup>			R = Reliatel			<b>Digit 18 – Through The Base Provisions</b>						<b>Digit 25 – System Monitoring Controls</b>		
<b>Digit 10 – Heating Capacity</b>			<b>Digit 11 – Minor Design Sequence</b>			0 = No Through The Base Provisions						0 = No Monitoring Controls		
<i>Note: (Applicable to Digit 1 T/W models only)</i>			H = Gas Heat - High			A = Through The Base Electric						1 = Clogged Filter Switch		
0 = No Heat			L = Gas Heat - Low			B = Through The Base Gas						2 = Fan Failure Switch		
G = 18 kW Electric Heat			X = Gas Heat - SS Ht Ex - Low			C = Through The Base Electric/Gas						3 = Discharge Air Sensing		
K = 27 kW Electric Heat			Z = Gas Heat - SS Ht Ex - High			D = Through The Base Access						4 = Clogged Filter Switch and Fan Failure		
N = 36 kW Electric Heat			<b>Digit 12, 13 – Service Sequence</b>			<b>Digit 19 – Disconnect Switch/ Circuit Breaker</b>						5 = Clogged Switch and Discharge Air Sensing		
P = 54 kW Electric Heat			<b>Digit 14 – Fresh Air Selection</b>			0 = No Disconnect/circuit break						6 = Fan Failure Switch and Discharge Air Sensing		
R = 72 kW Electric Heat			0 = No Fresh Air			1 = Unit Mounted Non-Fused Disconnect Switch						7 = Clogged Filter Switch, Fan Failure Switch and Discharge Air Sensing		
<i>Note: (Applicable to Digit 1 Y models only)</i>			A = Manual Damper			2 = Unit Mounted Circuit Breaker						A = Condensate Drain Pan Overflow Switch		
H = Gas Heat - High			B = Motorized Damper			<b>Digit 20 – Convenience Outlet Option</b>						B = Clogged Filter Switch and Condensate Drain Pan Overflow Switch		
L = Gas Heat - Low			D = Econ Dry Bulb w/ Barometric Relief			0 = Without Convenience Outlet						C = Fan Failure Switch and Condensate Drain Pan Overflow Switch		
X = Gas Heat - SS Ht Ex - Low			F = Econ Reference Enthalpy w/ Barometric Relief			1 = Unpowered Convenience Outlet						D = Discharge Air Sensing and Condensate Drain Pan Overflow Switch		
Z = Gas Heat - SS Ht Ex - High			H = Econ Comparative Enthalpy w/ Barometric Relief			2 = Powered Convenience Outlet						E = Clogged Filter Switch, Fan Failure Switch and Condensate Drain Pan Overflow Switch		

H = Clogged Filter Switch, Fan Failure Switch, Discharge Air Sensing and Condensate Drain Pan Overflow Switch

### Digit 26 - System Monitoring Controls

0 = No Monitoring Controls  
A = Demand Control Ventilation (CO<sub>2</sub>)<sup>12</sup>

### Digit 27 - Unit Hardware Enhancements

0 = No Enhancements  
1 = Stainless Steel Drain Pan

## Model Number Notes

1. TCI is for use with non-VariTrac systems and VariTrac systems.
2. Requires ReliaTel options module.
3. Requires Economizer.
4. Available factory installed on downflow AND horizontal units. Verify with ordering system.
5. Cannot be fused.
6. Must be factory installed when using Through-the-Base Options.
7. ReliaTel Options Module is required when ordering the following accessories (Factory- or Field-Installed Options): Clogged Filter Switch, Fan Fail Switch, Discharge Air Sensing Kit, Froststat, Ventilation Override.
8. Unit mounted disconnect and circuit breakers are mutually exclusive of each other.
9. Through-the-base electrical option or Horizontal Side Access must be ordered with either unit mounted disconnect or circuit breaker. When adding heat, must order Trane Electric Heat.
10. All Factory Installed Options are Built-to-Order. Check order services for estimated production cycle.
11. Available on Heat Pump (W) units only.
12. Demand Control Ventilation Option includes wiring only. The CO<sub>2</sub> sensor is a field-installed only option.
13. TCI is for use with non-VariTrac systems and VariTrac systems.  
**Note:** *\*Some Factory Installed Options (FIOPS) available for Downflow Air Discharge units only. Please verify with ordering system for availability.*



# General Data

**Table 3. TS\* general data**

Model	15–25 Tons Downflow and Horizontal Units			
	TS* 155FD	TS* 175FD	TS* 200FD	TS* 250FD
<b>Cooling Performance<sup>(a)</sup></b>				
ARI Gross Capacity kW (MBh)	44.8 (153)	51.2 (174.8)	62.7 (214.1)	68.3 (233.0)
COP/EER <sup>(b)</sup>	3.47 / 11.8	3.51 / 12.0	3.14 / 10.7	3.10 / 10.8
Nominal Airflow - m <sup>3</sup> /h (cfm)	7480 (4400)	9000 (5300)	10400 (6125)	12240 (7200)
ARI Airflow - m <sup>3</sup> /h (cfm)	44.0 (150)	49.8 (170.0)	61.0 (208.2)	66.0 (225.3)
ARI Net Capacity - kW (MBh)	13	14.6	20.0	21.6
System Power - kW	12.9	14.5	19.6	21.0
<b>Compressor</b>				
No./Type	2/Scroll	2/Scroll	2/Scroll	2/Scroll
<b>Sound Rating BELS<sup>(c)</sup></b>				
	9.0	9.2	9.2	9.2
<b>Outdoor Coil - Type</b>				
	Microchannel	Microchannel	Microchannel	Microchannel
Coil Width mm (in.)	25.4 (1)	25.4 (1)	25.4 (1)	25.4 (1)
Face Area - m <sup>2</sup> (sq. ft.)	3.27 (35.2)	3.27 (35.2)	3.27 (35.2)	3.27 (35.2)
Rows/Fins per inch	1 / 20	1 / 20	1 / 20	1 / 20
<b>Indoor Coil - Type</b>				
	Hi-Performance	Hi-Performance	Hi-Performance	Hi-Performance
Tube Size OD - in.	0.3125	0.3125	0.3125	0.3125
Face Area - m <sup>2</sup> (sq. ft.)	(2.42) 26	(2.42) 26	(2.42) 26	(2.42) 26
Rows/Fins per inch	3/ 15	4 / 15	4 / 15	4 / 15
Refrigerant Control	Short Orifice	Short Orifice	Short Orifice	Short Orifice
Drain Connection No./Size - in.	1/1.00 NPT	1/1.00 NPT	1/1.00 NPT	1/1.00 NPT
<b>Outdoor Fan - Type</b>				
	Propeller	Propeller	Propeller	Propeller
No. Used/Diameter - mm (in.)	2 / 660 (26)	2 / 660 (26)	2 / 660 (26)	2 / 710(28)
Drive Type/No. Speeds	Direct / 1	Direct / 1	Direct / 1	Direct / 1
Airflow - m <sup>3</sup> /h (cfm)	15630 (9200)	18860 (11100)	18000 (10600)	19880 (11700)
No. Motors/Power - W (HP)	2 / 250(0.33)	2 / 560(0.75)	2 / 560(0.75)	2 / 560(0.75)
Motor RPM	915	940	940	940
<b>Indoor Fan - Type</b>				
	FC Centrifugal	FC Centrifugal	FC Centrifugal	FC Centrifugal
No. Used	1	1	1	1
Diameter x Width - mm (in.)	457x457 (18x18)	457x457 (18x18)	457x457 (18x18)	457x457 (18x18)
Drive Type/No. Speeds	Belt / 1	Belt / 1	Belt / 1	Belt / 1
No. Motors	1	1	1	1
Standard/Oversized Motor Power — W (HP)	1500(2.0) / 2200(3.0)	2200(3.0) / 3700(5.0)	2200(3.0) / 3700(5.0)	3700(5.0) / N/A
Motor RPM - Standard/Oversized	1450 / 2850	2850 / 2920	2850 / 2920	2920/N/A



**TS\* General Data**
**Table 3. TS\* general data (continued)**

Model	15–25 Tons Downflow and Horizontal Units			
	TS* 155FD	TS* 175FD	TS* 200FD	TS* 250FD
<b>Filters—Type/Furnished</b>				
Type Furnished	Throwaway	Throwaway	Throwaway	Throwaway
Number Size Recommended				
Downflow—mm	(4)508x508x50 (4)508x635x50	(4)508x508x50 (4)508x635x50	(4)508x508x50 (4)508x635x50	(4)508x508x50 (4)508x635x50
Downflow—in	(4)20x20x2 (4)20x25x2	(4)20x20x2 (4)20x25x2	(4)20x20x2 (4)20x25x2	(4)20x20x2 (4)20x25x2
Horizontal—mm	(8)508x635x50	(8)508x635x50	(8)508x635x50	(8)508x635x50
Horizontal—in	(8)20x25x2	(8)20x25x2	(8)20x25x2	(8)20x25x2
<b>Refrigerant Charge</b>				
R-410A kg (lb) <sup>(d)</sup>	5.2/2.7 (11.4/6)	6.5/3.4 (14.4/7.6)	6.1/3.2 (13.5/7)	4.8/4.8 (10.5/10.5)

- (a) Cooling Performance is rated at 35°C (95°F) ambient, 26.7°C (80°F) entering dry bulb, 19.4°C (67°F) entering wet bulb. Gross capacity does not include the effect of fan motor heat. ARI capacity is net and includes the effect of fan motor heat. Units are suitable for operation ±20% of nominal airflow. Ratings shown are tested and certified in accordance with ARI Standard 210/240 or 340/360 certification program.
- (b) EER is rated at ARI conditions and in accordance with DOE test procedures.
- (c) Sound Ratings shown are tested in accordance with ARI Standard 270 or 370.
- (d) Refrigerant charge is an approximate value. For a more precise value, see unit nameplate and service instructions.



## General Data

YS\* General Data

**Table 4. YS\* general data**

Model	15–25 Tons Downflow and Horizontal Units							
	YS*155FD		YS*175FD		YS*200FD		YS*250FD	
<b>Cooling Performance<sup>(a)</sup></b>								
ARI Gross Capacity—kw (MBh))	44.8 (153)		51.2 (174.8)		62.7 (214.1)		68.3 (233.0)	
COP/EER <sup>(b)</sup>	3.47 / 11.8		3.51 / 12.0		3.14 / 10.7		3.10 / 10.8	
Nominal Airflow—m <sup>3</sup> /h (cfm)	7480 (4400)		5300		6125		7175	
ARI Airflow—m <sup>3</sup> /h (cfm)	44.0 (150)		49.8 (170.0)		61.0 (208.2)		66.0 (225.3)	
System Power—kW	13		14.6		20.0		21.6	
<b>Heating Performance<sup>(c)</sup></b>								
Heating Models	Low	High	Low	High	Low	High	Low	High
Heating Input—(MBh)	61.1(208.3)	85.5(291.7)	61.1(208.3)	85.5(291.7)	61.1(208.3)	97.7(333.3)	61.1(208.3)	97.7(333.3)
1st Stage (2 Stage Only)—(MBh)	42.7(145.8)	61.1(208.3)	42.7(145.8)	61.1(208.3)	42.7(145.8)	73.3(250.0)	42.7(145.8)	73.3(250.0)
Heating Output—(MBh)	49.6(169.2)	69.4(236.7)	49.6(169.2)	69.4(236.7)	49.6(169.2)	79.1(270.0)	49.6(169.2)	79.1(270.0)
1st Stage (2 Stage Only)—(MBh)	34.7(118.3)	49.6(169.2)	34.7(118.3)	49.6(169.2)	34.7(118.3)	59.3(202.5)	34.7(118.3)	59.3(202.5)
Steady State Efficiency %	23.7(81.0)	23.7(81.0)	23.7(81.0)	23.7(81.0)	23.7(81.0)	23.7(81.0)	23.7(81.0)	23.7(81.0)
<b>Numbers of Gas Heat Stages</b>								
Number of Gas Burners	1	1	1	1	1	1	1	1
Gas Connection Pipe Size—in.	1/2	3/4	1/2	3/4	1/2	3/4	1/2	3/4
<b>Compressor</b>								
Number/Type	2/Scroll		2/Scroll		2/Scroll		2/Scroll	
<b>Sound Rating BELS<sup>(d)</sup></b>								
	9.0		9.2		9.2		9.2	
<b>Outdoor Coil</b>								
Type	Microchannel		Microchannel		Microchannel		Microchannel	
Coil Width—mm (in.)	25.4 (1)		25.4 (1)		25.4 (1)		25.4 (1)	
Face Area—m <sup>3</sup> (sq. ft.)	3.27 (35.2)		3.27 (35.2)		3.27 (35.2)		3.27 (35.2)	
Rows / Fins per inch	1 / 20		1 / 20		1 / 20		1 / 20	
<b>Indoor Coil</b>								
Type	Hi-Performance		Hi-Performance		Hi-Performance		Hi-Performance	
Tube Size (in.) ID	0.3125		0.3125		0.3125		0.3125	
Face Area—m <sup>3</sup> (sq. ft.)	(2.42) 26		(2.42) 26		(2.42) 26		(2.42) 26	
Rows/Fins per inch	3/15		4/15		4/15		4/15	
Refrigerant Control	Short Orifice		Short Orifice		Short Orifice		Short Orifice	
Drain Connection Number/ Size—in.	1/1.00 NPT		1/1.00 NPT		1/1.00 NPT		1/1.00 NPT	
<b>Outdoor Fan</b>								
Type	Propeller		Propeller		Propeller		Propeller	
Number Used/Diameter—mm (in.)	2/660 (26)		2/660 (26)		2/660 (26)		2/710 (28)	
Drive Type/No. Speeds	Direct/1		Direct/1		Direct/1		Direct/1	
Airflow—m <sup>3</sup> /h (CFM)	15630 (9200)		18860 (11100)		18000 (10600)		19880 (11700)	
Number Motors/W (HP)	2/250(0.33)		2/560(0.75)		2/560(0.75)		2/560(0.75)	
Motor RPM	915		940		940		940	

YS\* General Data

Table 4. YS\* general data (continued)

Model	15–25 Tons Downflow and Horizontal Units			
	YS*155FD	YS*175FD	YS*200FD	YS*250FD
<b>Indoor Fan</b>				
Type	FC Centrifugal	FC Centrifugal	FC Centrifugal	FC Centrifugal
Number Used	1	1	1	1
Diameter x Width—mm (in.)	457x457 (18x18)	457x457 (18x18)	457x457 (18x18)	457x457 (18x18)
Drive Type/No. Speeds	Belt / 1	Belt / 1	Belt / 1	Belt / 1
Number Motors	1	1	1	1
Motor W (HP) (Standard/Oversized)	1500 (2.0) / 2200 (3.0)	2200 (3.0) / 3700 (5.0)	2200 (3.0) / 3700 (5.0)	3700 (5.0) / N/A
Motor RPM (Standard/Oversized)	1450 / 2850	2850 / 2920	2850 / 2920	2920/N/A
<b>Filters</b>				
Type Furnished	Throwaway	Throwaway	Throwaway	Throwaway
Number Size Recommended				
Downflow—mm	(4)508x508x50 (4)508x635x50	(4)508x508x50 (4)508x635x50	(4)508x508x50 (4)508x635x50	(4)508x508x50 (4)508x635x50
Downflow—in.	(4)20x20x2 (4)20x25x2	(4)20x20x2 (4)20x25x2	(4)20x20x2 (4)20x25x2	(4)20x20x2 (4)20x25x2
Horizontal—mm	(8)508x635x50	(8)508x635x50	(8)508x635x50	(8)508x635x50
Horizontal—in.	(8)20x25x2	(8)20x25x2	(8)20x25x2	(8)20x25x2
<b>Refrigerant Charge</b>				
R-410A kg (lb) <sup>(e)</sup>	5.2/2.7 (11.4/6)	6.5/3.4 (14.4/7.6)	6.1/3.2 (13.5/7)	4.8/4.8 (10.5/10.5)

- (a) Cooling Performance is rated at 35°C (95°F) ambient, 26.7°C (80°F) entering dry bulb, 19.4°C (67°F) entering wet bulb. Gross capacity does not include the effect of fan motor heat. ARI capacity is net and includes the effect of fan motor heat. Units are suitable for operation ±20% of nominal airflow. Ratings shown are tested and certified in accordance with ARI Standard 210/240 or 340/360 certification program.
- (b) EER is rated at ARI conditions and in accordance with DOE test procedures.
- (c) Heating performance unit settings and data were established under laboratory test conditions using American National Standards Institute standards. Ratings shown are for elevations up to 610 meters (2000 ft.). For elevations above 610 meters (2000 ft.), ratings should be reduced at the rate of 4% for each 305 meters (1000 ft.) above sea level.
- (d) Sound Rating shown is tested in accordance with ARI Standard 270 or 370.
- (e) Refrigerant charge is an approximate value. For a more precise value, see unit nameplate and service instructions.

**Table 5. WS\* general data**

Model	15–20 Tons Downflow and Horizontal Units	
	WS*155ED, ET	WS*200ED, ET
<b>Cooling Performance<sup>(a)</sup></b>		
ARI Gross Capacity—kW (MBh)	44.1 (150.7)	62.9 (214.8)
COP/EER <sup>(b)</sup>	3.3 (11.3)	2.9 (9.9)
Nominal Airflow—m <sup>3</sup> /h (cfm)	8500 (5000)	(11890) 7000
ARI Airflow—m <sup>3</sup> /h (cfm)	8500 (5000)	(11890) 7000
ARI Net Capacity—kW (MBh)	43.2 (147.5)	61.0 (208.5)
System Power—kW	13.1	21.0
<b>Heating Performance<sup>(a)</sup></b>		
High Temperature Capacity—kW (MBh)	41.8 (142.7)	61.4 (209.6)
COP	3.8	3.6
System Power—kW	11.0	17.2
<b>Compressor</b>		
Number/Type	2 / Scrolls	2 / Scrolls
<b>Sound Rating BELS<sup>(c)</sup></b>		
	9.0	9.2
<b>Outdoor Coil</b>		
Type	Hi-Performance	Hi-Performance
Refrigerant Control	Expansion Valve	Expansion Valve
Tube Size (in.) OD	0.3125	0.3125
Face Area-m <sup>3</sup> (sq. ft.)	3.3 (35.2)	4.0 (42.53)
Rows / Fins per inch	3 / 16	3 / 16
<b>Indoor Coil</b>		
Type	Hi-Performance	Hi-Performance
Tube Size (in.) ID	0.3125	0.3125
Face Area-m <sup>3</sup> (sq. ft.)	2.4 (26)	2.9 (31.42)
Rows / Fins per inch	4 / 15	4 / 15
Refrigerant Control	Short Orifice	Short Orifice
Drain Connection Number/Size (in.)	1/1.00 NPT	1/1.00 NPT
<b>Outdoor Fan</b>		
Type	Propeller	Propeller
Number Used/Diameter—mm (in.)	2 / 660 (26)	2 / 710(28)
Drive Type/No. Speeds	Direct / 1	Direct / 1
Airflow—m <sup>3</sup> /h (CFM)	15300 (9000)	20900 (12300)
Number Motors/W (HP)	2 / 250 (0.33)	2 / 560 (0.75)
Motor RPM	915	940

**WS\* General Data**
**Table 5. WS\* general data (continued)**

Model	15–20 Tons Downflow and Horizontal Units	
	WS*155ED, ET	WS*200ED, ET
<b>Indoor Fan</b>		
Type	FC Centrifugal	FC Centrifugal
Number Used	1	1
Diameter x Width—mm (in.)	457x457 (18x18)	457x457 (18x18)
Drive Type/No. Speeds	Belt / 1	Belt / 1
Number Motors	1	1
Motor W (HP) (Standard/Oversized)	1500 (2.0) / 2200 (3.0)	2200 (3.0) / 3700 (5.0)
Motor RPM (Standard/Oversized)	1450 / 2850	2850 / 2920
<b>Filters</b>		
Type Furnished	Throwaway	Throwaway
Number Size Recommended		
Downflow—mm	(4)508x508x50	(8)20x20x2 (4)20x16x2
Downflow	(4)508x635x50	(8)508x508x50
Downflow—in	(4)20x20x2 (4)20x25x2	(4)508x406x50
Horizontal—mm	(8)508x635x50	(12)508x508x50
Horizontal—in	(8)20x25x2	(12)20x20x2
<b>Refrigerant Charge</b>		
R-410A kg (lb) <sup>(d)</sup>	6.6 / 6.4 (14.5 / 14.2)	9.0 / 8.2 (19.75 / 18)

(a) Cooling Performance is rated at 35°C (95°F) ambient, 26.7°C (80°F) entering dry bulb, 19.4°C (67°F) entering wet bulb. Heating Performance is rated at 20°C (68°F) ambient, 8.3°C (47°F) entering dry bulb, 6.1°C (43°F) entering wet bulb. Gross capacity does not include the effect of fan motor heat. ARI capacity is net and includes the effect of fan motor heat. Units are suitable for operation to ±20% of nominal airflow. Rated in accordance with ARI Standard 210/240 or 340/360.

(b) EER is rated at ARI conditions and in accordance with DOE test procedures.

(c) Sound Rating shown is tested in accordance with ARI Standard 270 or 370.

(d) Refrigerant charge is an approximate value. For a more precise value, see unit nameplate and service instructions.



# Performance Data

**Table 6. Gross cooling capacities T/Y5\*155FD (SI)**

Airflow m <sup>3</sup> /h	Enter DB (°C)	Ambient Temperature (°C)																	
		30						35						40					
		Entering Wet Bulb Temperature (°C)																	
		16		19		22		16		19		22		16		19		22	
TGC	SHC	TGC	SHC	TGC	SHC	TGC	SHC	TGC	SHC	TGC	SHC	TGC	SHC	TGC	SHC	TGC	SHC		
7140	24	42.3	34.8	46.1	25.1	51.3	17.9	38.7	32.6	42.6	23.7	47.7	16.7	34.7	30.2	38.6	22.0	43.8	15.3
	27	44.2	41.1	47.1	33.6	51.3	20.4	41.0	38.8	43.9	32.1	48.1	19.6	37.4	36.3	40.3	30.2	44.5	18.5
	30	46.3	46.3	48.2	41.0	51.4	29.9	43.4	43.4	45.4	39.3	48.6	28.9	40.1	40.1	42.1	37.3	45.3	27.7
	33	48.5	48.5	49.4	47.2	51.7	38.3	45.9	45.9	46.9	45.4	49.2	37.2	43.0	43.0	44.0	43.3	46.3	35.8
7820	24	43.5	36.1	47.0	26.4	51.9	18.2	39.9	34.0	43.5	25.0	48.4	16.9	35.9	31.6	39.6	23.3	44.5	15.6
	27	45.5	42.6	48.1	35.0	52.0	21.7	42.3	40.3	44.9	33.5	48.9	20.9	38.7	37.8	41.3	31.6	45.3	19.8
	30	47.7	47.7	49.3	42.4	52.2	31.3	44.8	44.8	46.5	40.8	49.4	30.3	41.5	41.5	43.2	38.8	46.2	29.1
	33	49.9	49.9	50.6	48.7	52.6	39.7	47.4	47.4	48.1	46.9	50.1	38.6	44.7	44.5	45.2	44.8	47.2	37.2
8500	24	44.5	37.4	47.8	27.6	52.4	18.3	41.0	35.3	44.3	26.2	48.9	17.1	37.0	32.9	40.4	24.5	45.0	15.8
	27	46.6	43.9	49.0	36.3	52.6	22.9	43.4	41.7	45.8	34.7	49.4	22.1	39.8	39.1	42.2	32.9	45.9	21.0
	30	48.9	48.9	50.2	43.8	52.9	32.5	46.0	46.0	47.4	42.1	50.1	31.6	42.7	42.7	44.2	40.1	46.9	30.3
	33	51.2	51.2	51.6	50.1	53.3	41.0	48.7	48.7	49.1	48.3	50.8	40.0	46.2	46.2	46.2	46.2	48.0	38.6
9180	24	45.4	38.6	48.4	28.7	52.7	18.4	41.8	36.4	44.9	27.3	49.2	17.2	37.9	34.0	41.0	25.6	45.4	15.9
	27	47.6	45.2	49.7	37.4	53.0	24.0	44.4	42.9	46.5	35.9	49.9	23.1	40.8	40.4	42.9	34.1	46.3	22.0
	30	49.9	49.9	51.0	45.0	53.4	33.7	47.1	47.1	48.2	43.4	50.6	32.7	43.8	43.8	45.0	41.4	47.4	31.5
	33	52.3	52.3	52.4	51.5	53.9	42.3	49.5	49.5	50.0	49.7	51.4	41.2	47.1	47.1	47.1	47.1	48.6	39.8
Airflow m <sup>3</sup> /h	Enter DB (°C)	Ambient Temperature (°C)																	
		45						49						52					
		Entering Wet Bulb Temperature (°C)																	
		16		19		22		16		19		22		16		19		22	
TGC	SHC	TGC	SHC	TGC	SHC	TGC	SHC	TGC	SHC	TGC	SHC	TGC	SHC	TGC	SHC	TGC	SHC		
7140	24	30.3	27.5	34.3	20.0	39.5	13.8	28.0	26.0	31.9	18.9	37.1	13.0	25.5	24.5	29.5	17.7	34.7	12.1
	27	33.3	33.3	36.3	28.1	40.5	17.1	31.1	31.1	34.1	26.9	38.4	16.2	28.9	28.9	31.8	25.7	36.1	15.3
	30	36.4	36.4	38.4	35.1	41.7	26.1	34.4	34.4	36.4	33.8	39.7	25.3	32.3	32.3	34.3	32.5	37.6	24.3
	33	40.6	40.6	40.6	40.6	43.0	34.1	38.8	38.8	38.8	38.8	41.1	33.1	36.9	36.9	36.9	36.9	39.2	32.1
7820	24	31.6	28.9	35.2	21.3	40.2	14.1	29.2	27.4	32.9	20.2	37.8	13.2	26.8	25.9	30.5	19.0	35.4	12.4
	27	34.6	34.6	37.3	29.5	41.3	18.4	32.5	32.5	35.2	28.3	39.2	17.5	30.2	30.2	32.9	27.1	36.9	16.6
	30	37.8	37.8	39.6	36.5	42.6	27.5	35.8	35.8	37.6	35.3	40.6	26.6	33.7	33.7	35.5	34.0	38.5	25.7
	33	41.9	41.9	41.9	41.9	43.9	35.5	40.0	40.0	40.0	40.0	42.1	34.6	38.1	38.1	38.1	38.1	40.2	33.6
8500	24	32.6	30.2	36.0	22.5	40.7	14.2	30.3	28.7	33.7	21.4	38.4	13.4	27.9	27.2	31.3	20.2	36.0	12.6
	27	35.8	35.8	38.2	30.8	41.9	19.6	33.6	33.6	36.1	29.6	39.8	18.7	31.4	31.4	33.8	28.4	37.5	17.8
	30	39.1	39.1	40.5	37.9	43.3	28.8	37.1	37.1	38.5	36.7	41.3	27.9	35.0	35.0	36.5	35.3	39.2	27.0
	33	42.9	42.9	42.9	42.9	44.7	36.9	41.1	41.1	41.1	41.1	42.9	36.0	39.2	39.2	39.2	39.2	41.0	34.9
9180	24	33.6	31.3	36.7	23.6	41.1	14.4	31.2	29.9	34.4	22.5	38.8	13.6	28.8	28.3	31.9	21.3	36.4	12.7
	27	36.8	36.8	39.0	32.0	42.4	20.6	34.7	34.7	36.8	30.8	40.3	19.8	32.4	32.4	34.6	29.5	38.0	18.9
	30	40.2	40.2	41.3	39.2	43.8	30.0	38.2	38.2	39.4	37.9	41.8	29.1	36.1	36.1	37.3	36.6	39.8	28.2
	33	43.8	43.8	43.8	43.8	45.3	38.2	42.0	42.0	42.0	42.0	43.5	37.2	40.1	40.1	40.1	40.1	41.6	36.2

**Notes:**

1. All capacities shown are gross and have not considered indoor fan heat.
2. TGC = Total gross capacity (kW)
3. SHC = Sensible heat capacity (kW)

**Gross Cooling Capacities**
**Table 7. Gross cooling capacities T/YS\*155FD (IP)**

Airflow CFM	Enter DB (°F)	Ambient Temperature (°F)																	
		85						95						105					
		Entering Wet Bulb Temperature (°F)																	
		61		67		73		61		67		73		61		67		73	
TGC	SHC	TGC	SHC	TGC	SHC	TGC	SHC	TGC	SHC	TGC	SHC	TGC	SHC	TGC	SHC	TGC	SHC		
4200	75	144.2	118.6	157.4	85.8	174.9	61.2	132.1	111.3	145.3	81.0	162.9	57.0	118.5	103.0	131.8	75.1	149.4	52.3
	80	151.0	140.2	160.8	114.7	175.0	69.7	139.9	132.5	149.9	109.5	164.2	66.9	127.5	123.8	137.5	103.2	151.9	63.0
	85	158.0	158.0	164.5	139.8	175.4	102.1	148.2	148.2	154.8	134.1	165.8	98.8	136.9	136.9	143.6	127.3	154.7	94.5
	90	165.4	165.4	168.6	161.0	176.2	130.5	156.7	156.7	160.1	154.8	167.8	126.8	146.6	146.6	150.1	147.6	157.9	122.0
4600	75	148.3	123.2	160.5	90.2	177.1	62.0	136.2	116.0	148.5	85.4	165.1	57.8	122.6	107.8	135.0	79.6	151.8	53.1
	80	155.3	145.2	164.2	119.4	177.5	74.1	144.3	137.5	153.4	114.1	166.7	71.3	132.0	128.8	141.1	107.9	154.5	67.4
	85	162.6	162.6	168.2	144.7	178.2	106.7	152.8	152.8	158.6	139.0	168.6	103.4	141.6	141.6	147.5	132.3	157.6	99.2
	90	170.3	170.3	172.6	166.2	179.3	135.4	161.7	161.7	164.1	160.0	170.9	131.7	152.6	151.7	154.2	152.9	161.0	127.0
5000	75	151.8	127.6	163.1	94.2	178.7	62.6	139.8	120.4	151.1	89.4	166.8	58.4	126.3	112.1	137.7	83.6	153.5	53.7
	80	159.1	149.8	167.1	123.7	179.4	78.1	148.2	142.1	156.3	118.5	168.7	75.3	135.9	133.5	144.1	112.2	156.6	71.5
	85	166.7	166.7	171.4	149.3	180.4	111.0	157.0	157.0	161.8	143.7	170.9	107.8	145.8	145.8	150.7	137.0	159.9	103.5
	90	174.6	174.6	176.0	171.1	181.8	140.0	166.1	166.1	167.6	165.0	173.4	136.3	157.7	157.7	157.7	157.7	163.7	131.6
5400	75	154.8	131.5	165.1	97.9	179.8	62.9	142.8	124.3	153.2	93.1	168.0	58.8	129.4	116.1	139.9	87.3	154.8	54.2
	80	162.3	154.1	169.4	127.7	180.8	81.7	151.5	146.4	158.7	122.5	170.2	79.0	139.3	137.8	146.5	116.2	158.1	75.2
	85	170.2	170.2	174.0	153.6	182.1	115.0	160.6	160.6	164.4	147.9	172.6	111.7	149.5	149.5	153.4	141.3	161.7	107.5
	90	178.4	178.4	178.9	175.6	183.8	144.3	168.8	168.8	170.5	169.5	175.4	140.6	160.7	160.7	160.7	160.7	165.7	135.9
5800	75	157.2	135.2	166.6	101.2	180.4	63.1	145.2	128.0	154.8	96.4	168.6	59.0	131.9	119.8	141.5	90.7	155.4	54.4
	80	165.0	158.0	171.2	131.3	181.7	85.1	154.3	150.3	160.5	126.1	171.1	82.3	142.1	141.7	148.4	119.9	159.0	78.6
	85	173.2	173.2	176.0	157.5	183.2	118.5	163.6	163.6	166.5	151.8	173.8	115.3	152.6	152.6	155.6	145.2	163.0	111.1
	90	179.5	179.5	181.3	179.8	185.2	148.2	172.9	172.9	172.9	172.9	176.9	144.5	163.2	163.2	163.2	163.2	167.3	139.8
Airflow CFM	Enter DB (°F)	Ambient Temperature (°F)																	
		115						120						125					
		Entering Wet Bulb Temperature (°F)																	
		61		67		73		61		67		73		61		67		73	
TGC	SHC	TGC	SHC	TGC	SHC	TGC	SHC	TGC	SHC	TGC	SHC	TGC	SHC	TGC	SHC	TGC	SHC		
4200	75	103.5	93.8	116.9	68.3	134.6	47.1	95.4	88.8	108.9	64.5	126.7	44.3	87.0	83.5	100.5	60.5	118.4	41.4
	80	113.7	113.7	123.8	95.9	138.3	58.2	106.2	106.2	116.4	91.9	130.9	55.4	98.4	98.4	108.6	87.6	123.2	52.3
	85	124.2	124.2	131.1	119.6	142.2	89.2	117.4	117.4	124.3	115.4	135.5	86.2	110.2	110.2	117.1	110.9	128.3	82.9
	90	138.7	138.7	138.7	138.7	146.5	116.3	132.4	132.4	132.4	132.4	140.4	113.0	125.9	125.9	125.9	125.9	133.8	109.5
4600	75	107.7	98.5	120.2	72.7	137.0	47.9	99.7	93.5	112.2	69.0	129.1	45.2	91.3	88.3	103.9	64.9	120.8	42.3
	80	118.2	118.2	127.4	100.6	140.9	62.6	110.8	110.8	120.0	96.6	133.6	59.8	103.0	103.0	112.3	92.4	125.9	56.8
	85	129.1	129.1	134.9	124.6	145.2	93.9	122.2	122.2	128.2	120.4	138.4	90.9	115.0	115.0	121.0	115.9	131.4	87.6
	90	142.8	142.8	142.8	142.8	149.8	121.3	136.6	136.6	136.6	136.6	143.6	118.0	130.1	130.1	130.1	130.1	137.1	114.6
5000	75	111.4	102.9	122.9	76.8	138.8	48.6	103.4	97.9	115.0	73.1	130.9	45.8	95.1	92.7	106.7	69.0	122.7	42.9
	80	122.2	122.2	130.4	105.0	143.0	66.7	114.8	114.8	123.1	101.0	135.7	63.9	107.1	107.1	115.4	96.8	128.1	60.9
	85	133.3	133.3	138.3	129.3	147.6	98.3	126.5	126.5	131.5	125.1	140.9	95.3	119.4	119.4	124.4	120.6	133.8	92.0
	90	146.4	146.4	146.4	146.4	152.5	125.9	140.3	140.3	140.3	140.3	146.3	122.7	133.8	133.8	133.8	133.8	139.9	119.2
5400	75	114.5	106.9	125.1	80.6	140.1	49.0	106.6	102.0	117.2	76.8	132.3	46.3	98.3	96.7	109.0	72.8	124.1	43.4
	80	125.6	125.6	132.9	109.0	144.6	70.4	118.2	118.2	125.6	105.0	137.3	67.7	110.5	110.5	118.0	100.8	129.7	64.6
	85	137.0	137.0	141.0	133.6	149.4	102.3	130.2	130.2	134.3	129.4	142.8	99.3	123.1	123.1	127.2	124.9	135.7	96.0
	90	149.5	149.5	149.5	149.5	154.6	130.2	143.4	143.4	143.4	143.4	148.5	127.0	136.9	136.9	136.9	136.9	142.1	123.6
5800	75	117.1	110.6	126.8	84.0	140.8	49.3	109.2	105.6	118.9	80.2	133.0	46.6	100.9	100.4	110.7	76.2	124.8	43.7
	80	128.5	128.5	134.9	112.7	145.6	73.8	121.1	121.1	127.6	108.7	138.4	71.0	113.5	113.5	120.0	104.5	130.8	68.0
	85	140.2	140.2	143.3	137.6	150.7	105.9	133.4	133.4	136.6	133.4	144.1	103.0	128.2	128.2	129.5	128.9	137.1	99.7
	90	152.0	152.0	152.0	152.0	156.2	134.2	145.9	145.9	145.9	145.9	150.1	131.0	139.4	139.4	139.4	139.4	143.7	127.5

**Notes:**

1. All capacities shown are gross and have not considered indoor fan heat.
2. TGC = Total gross capacity (kW)
3. SHC = Sensible heat capacity (kW)



**Performance Data**

*Gross Cooling Capacities*

**Table 8. Gross cooling capacities T/YS\*175FD (SI)**

Airflow m <sup>3</sup> /h	Enter DB (°C)	Ambient Temperature (°C)																	
		30						35						40					
		Entering Wet Bulb Temperature (°C)																	
		16		19		22		16		19		22		16		19		22	
TGC	SHC	TGC	SHC	TGC	SHC	TGC	SHC	TGC	SHC	TGC	SHC	TGC	SHC	TGC	SHC	TGC	SHC		
7985	24	46.9	39.4	52.1	29.4	59.4	20.8	42.1	36.6	47.2	27.5	54.5	19.1	36.7	33.4	41.8	25.2	49.0	17.1
	27	49.2	46.4	53.1	38.6	59.1	24.9	45.1	43.8	49.0	36.8	54.9	24.0	40.4	40.4	44.2	34.5	50.1	22.7
	30	51.8	51.8	54.3	46.4	59.0	34.9	48.4	48.4	50.9	44.8	55.5	34.1	44.4	44.4	46.9	42.6	51.4	32.8
	33	54.5	54.5	55.7	53.0	59.0	43.6	51.8	51.8	53.0	51.4	56.3	42.9	49.2	48.6	49.7	49.3	52.9	41.7
8750	24	48.2	40.9	53.2	30.9	60.3	21.1	43.4	38.1	48.3	29.0	55.4	19.4	38.0	34.9	42.9	26.7	49.9	17.5
	27	50.6	48.0	54.2	40.1	60.0	26.4	46.5	45.3	50.1	38.3	55.8	25.5	41.8	41.8	45.4	36.1	51.1	24.2
	30	53.1	53.1	55.5	48.0	59.9	36.4	49.8	49.8	52.1	46.3	56.5	35.7	45.8	45.8	48.1	44.2	52.4	34.4
	33	55.9	55.9	57.0	54.7	60.1	45.2	53.3	53.3	54.3	53.1	57.3	44.5	50.5	50.5	51.0	51.0	54.0	43.3
9515	24	49.4	42.4	54.2	32.4	61.1	21.4	44.6	39.6	49.4	30.5	56.2	19.7	39.3	36.3	44.0	28.1	50.8	17.8
	27	51.8	49.5	55.3	41.6	60.9	27.9	47.8	46.8	51.2	39.9	56.7	27.1	43.1	43.1	46.5	37.6	52.0	25.7
	30	54.4	54.4	56.6	49.6	60.8	38.0	51.1	51.1	53.2	47.9	57.4	37.2	47.2	47.2	49.3	45.7	53.4	35.9
	33	57.3	57.3	58.1	56.3	61.0	46.8	54.7	54.7	55.5	54.7	58.3	46.1	52.2	52.2	52.2	52.2	55.0	44.9
10280	24	50.5	43.8	55.1	33.8	61.8	21.6	45.8	41.1	50.3	32.0	57.0	19.9	40.4	37.8	45.0	29.6	51.5	18.0
	27	52.9	51.0	56.2	43.1	61.6	29.4	49.0	48.4	52.2	41.4	57.5	28.6	44.4	44.4	47.6	39.1	52.8	27.2
	30	55.6	55.6	57.6	51.2	61.7	39.6	52.4	52.4	54.3	49.5	58.3	38.8	48.5	48.5	50.4	47.3	54.3	37.5
	33	58.5	58.5	59.2	57.9	61.9	48.4	56.0	56.0	56.6	56.3	59.2	47.7	53.4	53.4	53.4	53.4	56.0	46.5
11045	24	51.5	45.3	55.9	35.3	62.4	21.8	46.8	42.5	51.2	33.4	57.6	20.2	41.5	39.2	45.9	31.0	52.2	18.3
	27	54.0	52.5	57.1	44.6	62.3	30.9	50.1	49.9	53.1	42.8	58.2	30.0	45.5	45.5	48.5	40.6	53.6	28.6
	30	56.8	56.8	58.5	52.7	62.4	41.1	53.5	53.5	55.3	51.0	59.0	40.3	49.7	49.7	51.4	48.8	55.1	39.0
	33	59.7	59.7	60.2	59.5	62.7	50.0	57.6	57.6	57.6	57.6	60.1	49.3	54.4	54.4	54.4	54.4	56.8	48.1
Airflow m <sup>3</sup> /h	Enter DB (°C)	Ambient Temperature (°C)																	
		45						49						52					
		Entering Wet Bulb Temperature (°C)																	
		16		19		22		16		19		22		16		19		22	
TGC	SHC	TGC	SHC	TGC	SHC	TGC	SHC	TGC	SHC	TGC	SHC	TGC	SHC	TGC	SHC	TGC	SHC		
7985	24	30.7	29.6	35.7	22.4	42.8	15.0	27.5	27.5	32.5	20.7	39.6	13.8	24.1	24.1	29.1	19.0	36.1	12.6
	27	35.2	35.2	38.9	31.8	44.7	20.8	32.3	32.3	36.0	30.2	41.8	19.7	29.3	29.3	32.9	28.5	38.7	18.4
	30	39.8	39.8	42.2	39.9	46.7	31.0	37.3	37.3	39.7	38.4	44.1	29.9	36.6	34.7	37.0	36.7	41.4	28.7
	33	45.8	45.8	45.8	45.8	48.9	40.0	43.6	43.6	43.6	43.6	46.7	38.9	41.3	41.3	41.3	41.3	44.4	37.8
8750	24	32.1	31.1	36.9	23.8	43.8	15.3	28.8	28.8	33.7	22.2	40.6	14.2	25.5	25.5	30.3	20.5	37.1	13.0
	27	36.6	36.6	40.1	33.3	45.7	22.3	33.7	33.7	37.2	31.7	42.8	21.2	30.7	30.7	34.2	30.0	39.8	19.9
	30	41.3	41.3	43.5	41.5	47.8	32.6	38.8	38.8	41.0	39.9	45.2	31.5	38.0	38.0	38.3	38.3	42.6	30.3
	33	47.1	47.1	47.1	47.1	50.1	41.6	45.0	45.0	45.0	45.0	47.9	40.5	42.7	42.7	42.7	42.7	45.6	39.4
9515	24	33.3	32.6	38.0	25.3	44.7	15.7	30.2	30.2	34.8	23.6	41.5	14.5	26.8	26.8	31.4	21.9	38.1	13.3
	27	37.9	37.9	41.3	34.8	46.7	23.8	35.1	35.1	38.4	33.2	43.8	22.7	32.1	32.1	35.4	31.5	40.7	21.4
	30	42.7	42.7	44.7	43.0	48.8	34.1	40.2	40.2	42.2	41.5	46.3	33.1	39.6	39.6	39.6	39.6	43.6	31.8
	33	48.4	48.4	48.4	48.4	51.1	43.2	46.2	46.2	46.2	46.2	49.0	42.1	44.0	44.0	44.0	44.0	46.7	41.0
10280	24	34.6	34.0	39.0	26.7	45.5	15.9	31.4	31.4	35.8	25.1	42.3	14.8	28.1	28.1	32.5	23.3	38.9	13.6
	27	39.2	39.2	42.3	36.3	47.5	25.3	36.4	36.4	39.5	34.7	44.7	24.2	33.4	33.4	36.5	33.0	41.6	22.9
	30	44.0	44.0	45.8	44.6	49.7	35.7	42.9	41.6	43.4	43.0	47.2	34.6	40.7	40.7	40.7	40.7	44.6	33.4
	33	49.6	49.6	49.6	49.6	52.1	44.8	47.4	47.4	47.4	47.4	50.0	43.7	45.2	45.2	45.2	45.2	47.7	42.6
11045	24	35.7	35.4	39.9	28.1	46.3	16.2	32.5	32.5	36.8	26.5	43.1	15.1	29.2	29.2	33.4	24.7	39.7	13.9
	27	40.4	40.4	43.3	37.8	48.3	26.8	37.6	37.6	40.5	36.2	45.5	25.6	34.6	34.6	37.5	34.4	42.5	24.4
	30	45.3	45.3	46.9	46.1	50.6	37.2	44.4	44.4	44.4	44.4	48.1	36.1	41.8	41.8	41.8	41.8	45.4	34.9
	33	50.7	50.7	50.7	50.7	53.0	46.4	48.5	48.5	48.5	48.5	50.9	45.3	46.3	46.3	46.3	46.3	48.6	44.1

**Notes:**

1. All capacities shown are gross and have not considered indoor fan heat.
2. TGC = Total gross capacity (kW)
3. SHC = Sensible heat capacity (kW)



**Gross Cooling Capacities**
**Table 9. Gross cooling capacities T/YS\*175FD (IP)**

Airflow CFM	Enter DB (°F)	Ambient Temperature (°F)																	
		85						95						105					
		Entering Wet Bulb Temperature (°F)																	
		61		67		73		61		67		73		61		67		73	
TGC	SHC	TGC	SHC	TGC	SHC	TGC	SHC	TGC	SHC	TGC	SHC	TGC	SHC	TGC	SHC	TGC	SHC		
4700	75	160.0	134.4	177.8	100.3	202.7	70.9	143.6	125.0	161.2	94.0	185.9	65.1	125.1	113.9	142.5	86.0	167.0	58.5
	80	168.0	158.5	181.2	131.5	201.6	84.8	154.0	149.4	167.1	125.6	187.2	81.9	138.0	138.0	150.9	117.8	170.8	77.3
	85	176.6	176.6	185.3	158.4	201.2	118.9	165.0	165.0	173.6	152.7	189.3	116.3	151.5	151.5	159.9	145.3	175.3	111.9
	90	185.9	185.9	190.1	180.9	201.4	148.6	176.8	176.8	180.8	175.5	192.0	146.3	167.8	165.7	169.5	168.3	180.5	142.2
5150	75	164.3	139.5	181.4	105.3	205.6	72.0	148.0	130.1	165.0	99.0	189.0	66.1	129.7	119.0	146.4	91.0	170.2	59.6
	80	172.5	163.7	185.1	136.8	204.7	90.1	158.6	154.6	171.0	130.8	190.5	87.1	142.7	142.7	154.9	123.0	174.2	82.5
	85	181.3	181.3	189.4	163.9	204.5	124.3	169.9	169.9	177.8	158.1	192.7	121.7	156.4	156.4	164.1	150.6	178.9	117.3
	90	190.7	190.7	194.3	186.5	205.0	154.2	181.8	181.8	185.2	181.1	195.6	151.8	172.2	172.2	174.0	173.9	184.3	147.7
5600	75	168.4	144.5	184.8	110.4	208.3	72.9	152.2	135.1	168.4	104.1	191.8	67.1	134.0	124.0	150.1	96.0	173.2	60.6
	80	176.7	169.0	188.6	142.0	207.6	95.2	163.0	159.8	174.7	136.0	193.5	92.3	147.2	147.2	158.7	128.2	177.4	87.6
	85	185.7	185.7	193.1	169.2	207.6	129.7	174.4	174.4	181.6	163.5	195.9	127.0	161.1	161.1	168.1	156.0	182.2	122.6
	90	195.3	195.3	198.2	192.1	208.2	159.7	186.5	186.5	189.2	186.6	199.0	157.3	178.2	178.2	178.2	178.2	187.8	153.2
6050	75	172.1	149.5	187.9	115.4	210.7	73.8	156.1	140.1	171.7	109.0	194.3	68.0	138.0	128.9	153.4	100.9	175.8	61.5
	80	180.6	174.2	191.9	147.2	210.2	100.4	167.0	165.0	178.1	141.1	196.2	97.4	151.4	151.4	162.3	133.3	180.2	92.7
	85	189.8	189.8	196.6	174.6	210.4	135.0	178.7	178.7	185.2	168.8	198.8	132.3	165.5	165.5	171.8	161.3	185.3	127.9
	90	199.7	199.7	201.9	197.6	211.2	165.2	191.1	191.1	193.0	192.1	202.1	162.8	182.0	182.0	182.0	182.0	191.0	158.7
6500	75	175.6	154.5	190.7	120.3	212.9	74.5	159.7	145.0	174.6	113.9	196.6	68.8	141.7	133.8	156.4	105.8	178.2	62.4
	80	184.3	179.3	194.9	152.3	212.5	105.5	170.8	170.1	181.2	146.2	198.7	102.5	155.3	155.3	165.5	138.4	182.8	97.7
	85	193.7	193.7	199.7	179.9	212.9	140.3	182.6	182.6	188.5	174.1	201.5	137.5	169.6	169.6	175.2	166.5	188.0	133.1
	90	203.7	203.7	205.3	203.1	213.9	170.7	196.5	196.5	196.5	196.5	204.9	168.2	185.7	185.7	185.7	185.7	193.9	164.1
Airflow CFM	Enter DB (°F)	Ambient Temperature (°F)																	
		115						120						125					
		Entering Wet Bulb Temperature (°F)																	
		61		67		73		61		67		73		61		67		73	
TGC	SHC	TGC	SHC	TGC	SHC	TGC	SHC	TGC	SHC	TGC	SHC	TGC	SHC	TGC	SHC	TGC	SHC		
4700	75	104.7	101.1	121.9	76.3	146.2	51.2	93.7	93.7	110.8	70.8	135.0	47.2	82.2	82.2	99.2	64.8	123.3	43.1
	80	120.0	120.0	132.6	108.4	152.4	70.9	110.2	110.2	122.8	103.0	142.5	67.1	99.9	99.9	112.4	97.2	132.0	62.9
	85	135.9	135.9	144.1	136.1	159.3	105.9	127.3	127.3	135.4	130.9	150.6	102.2	125.0	118.3	126.3	125.2	141.4	98.1
	90	156.2	156.2	156.2	156.2	166.9	136.4	148.8	148.8	148.8	148.8	159.4	132.8	140.8	140.8	140.8	140.8	151.4	128.9
5150	75	109.4	106.1	125.9	81.3	149.5	52.3	98.4	98.4	114.9	75.7	138.4	48.4	87.0	87.0	103.3	69.8	126.7	44.4
	80	124.8	124.8	136.8	113.6	156.0	76.1	115.1	115.1	127.0	108.2	146.0	72.3	104.9	104.9	116.7	102.4	135.6	68.0
	85	141.0	141.0	148.5	141.4	163.1	111.2	132.5	132.5	139.9	136.2	154.4	107.5	129.5	129.5	130.8	130.5	145.2	103.4
	90	160.8	160.8	160.8	160.8	170.9	141.9	153.4	153.4	153.4	153.4	163.4	138.3	145.5	145.5	145.5	145.5	155.4	134.4
5600	75	113.8	111.1	129.6	86.2	152.6	53.4	102.9	102.9	118.7	80.7	141.5	49.5	91.5	91.5	107.2	74.7	129.9	45.5
	80	129.4	129.4	140.8	118.7	159.2	81.2	119.8	119.8	131.0	113.3	149.4	77.4	109.6	109.6	120.8	107.5	139.0	73.1
	85	145.7	145.7	152.6	146.8	166.5	116.5	137.3	137.3	144.1	141.5	157.9	112.8	135.0	135.0	135.0	135.0	148.8	108.6
	90	165.1	165.1	165.1	165.1	174.5	147.4	157.8	157.8	157.8	157.8	167.1	143.8	150.0	150.0	150.0	150.0	159.2	139.8
6050	75	117.9	116.0	133.1	91.1	155.3	54.4	107.1	107.1	122.2	85.6	144.3	50.5	95.8	95.8	110.7	79.6	132.8	46.5
	80	133.7	133.7	144.4	123.8	162.2	86.3	124.1	124.1	134.7	118.4	152.4	82.4	114.0	114.0	124.5	112.5	142.1	78.1
	85	150.2	150.2	156.4	152.0	169.7	121.7	146.5	141.9	147.9	146.7	161.1	118.0	139.0	139.0	139.0	139.0	152.0	113.9
	90	169.1	169.1	169.1	169.1	177.8	152.8	161.8	161.8	161.8	161.8	170.5	149.2	154.1	154.1	154.1	154.1	162.6	145.2
6500	75	121.7	120.9	136.3	96.0	157.8	55.2	111.0	111.0	125.4	90.4	146.9	51.4	99.7	99.7	114.0	84.4	135.4	47.4
	80	137.8	137.8	147.8	128.8	164.9	91.3	128.2	128.2	138.1	123.4	155.1	87.4	118.2	118.2	128.0	117.5	144.9	83.1
	85	154.5	154.5	160.0	157.2	172.5	126.9	151.6	151.6	151.6	151.6	164.0	123.2	142.6	142.6	142.6	142.6	155.0	119.0
	90	172.8	172.8	172.8	172.8	180.9	158.2	165.6	165.6	165.6	165.6	173.6	154.6	157.9	157.9	157.9	157.9	165.8	150.5

**Notes:**

1. All capacities shown are gross and have not considered indoor fan heat.
2. TGC = Total gross capacity (kW)
3. SHC = Sensible heat capacity (kW)



**Performance Data**

*Gross Cooling Capacities*

**Table 10. Gross cooling capacities T/YS\*200FD (SI)**

Airflow m <sup>3</sup> /h	Enter DB (°C)	Ambient Temperature (°C)																	
		30						35						40					
		Entering Wet Bulb Temperature (°C)																	
		16		19		22		16		19		22		16		19		22	
TGC	SHC	TGC	SHC	TGC	SHC	TGC	SHC	TGC	SHC	TGC	SHC	TGC	SHC	TGC	SHC	TGC	SHC		
9005	24	57.5	47.4	63.3	35.1	71.6	25.1	52.6	44.6	58.4	33.3	66.6	23.3	47.6	41.6	53.2	31.2	61.3	21.5
	27	60.1	55.6	64.7	46.1	71.7	29.7	55.9	52.8	60.3	44.2	67.2	28.8	51.3	49.7	55.7	42.0	62.5	27.6
	30	62.7	62.1	65.9	55.3	71.6	41.7	58.9	58.9	62.1	53.4	67.7	40.7	55.0	55.0	58.0	51.2	63.5	39.5
	33	65.1	65.1	67.1	62.9	71.4	52.0	61.9	61.9	63.8	60.9	68.0	51.0	58.5	58.5	60.2	58.7	64.4	49.7
9940	24	59.7	49.7	65.2	37.1	73.1	25.6	54.8	46.9	60.2	35.3	68.1	23.8	49.7	43.9	55.0	33.2	62.8	22.0
	27	62.4	58.0	66.6	48.2	73.2	31.5	58.0	55.2	62.1	46.3	68.7	30.6	53.5	52.1	57.5	44.1	64.0	29.4
	30	64.9	64.6	67.8	57.5	73.2	43.6	61.1	61.1	63.9	55.6	69.2	42.6	57.1	57.1	59.8	53.4	65.0	41.4
	33	67.4	67.4	69.0	65.2	73.0	54.0	64.1	64.1	65.6	63.3	69.6	53.0	60.6	60.6	62.1	61.1	65.9	51.8
10875	24	61.5	51.6	66.7	38.7	74.3	26.0	56.6	48.8	61.7	36.9	69.2	24.2	51.5	45.8	56.5	34.8	63.9	22.4
	27	64.2	60.1	68.1	49.9	74.4	33.0	59.8	57.2	63.6	48.0	69.8	32.0	55.3	54.2	58.9	45.9	65.1	30.9
	30	66.8	66.8	69.3	59.4	74.3	45.2	63.0	63.0	65.4	57.5	70.3	44.2	58.9	58.9	61.3	55.3	66.1	43.0
	33	69.2	69.2	70.5	67.2	74.2	55.8	66.0	66.0	67.1	65.3	70.7	54.7	62.9	62.5	63.5	63.1	67.1	53.5
11810	24	63.0	53.2	67.8	40.0	75.0	26.3	58.1	50.4	62.8	38.2	69.9	24.5	52.9	47.4	57.5	36.1	64.6	22.6
	27	65.7	61.7	69.2	51.3	75.2	34.1	61.3	58.9	64.7	49.4	70.6	33.1	56.7	55.9	60.0	47.3	65.8	32.0
	30	68.3	68.3	70.5	60.9	75.2	46.4	64.4	64.4	66.6	59.0	71.1	45.5	60.4	60.4	62.4	56.9	66.9	44.2
	33	70.8	70.8	71.7	68.9	75.0	57.1	67.4	67.4	68.3	66.9	71.5	56.1	64.6	64.6	64.6	64.6	67.8	54.8
12745	24	64.1	54.4	68.6	40.9	75.5	26.4	59.1	51.6	63.5	39.1	70.3	24.6	53.9	48.6	58.2	37.0	64.9	22.7
	27	66.8	63.1	70.0	52.4	75.6	34.8	62.4	60.3	65.5	50.5	71.0	33.9	57.7	57.2	60.7	48.4	66.2	32.7
	30	69.4	69.4	71.3	62.1	75.6	47.3	65.5	65.5	67.3	60.2	71.5	46.4	61.4	61.4	63.1	58.0	67.3	45.1
	33	71.9	71.9	72.5	70.2	75.5	58.1	68.6	68.6	69.1	68.2	72.0	57.1	65.4	65.4	65.4	65.4	68.2	55.9

Airflow m <sup>3</sup> /h	Enter DB (°C)	Ambient Temperature (°C)																	
		45						49						52					
		Entering Wet Bulb Temperature (°C)																	
		16		19		22		16		19		22		16		19		22	
TGC	SHC	TGC	SHC	TGC	SHC	TGC	SHC	TGC	SHC	TGC	SHC	TGC	SHC	TGC	SHC	TGC	SHC		
9005	24	42.3	38.3	47.9	28.8	55.9	19.6	39.5	36.6	45.1	27.6	53.0	18.6	36.7	34.8	42.2	26.2	NA	NA
	27	46.6	46.4	50.8	39.7	57.6	26.1	44.1	44.1	48.3	38.4	55.0	25.3	41.6	41.6	45.8	37.0	NA	NA
	30	50.7	50.7	53.7	48.8	59.1	38.0	48.5	48.5	51.5	47.5	56.8	37.2	46.3	46.3	49.2	46.1	NA	NA
	33	55.9	55.9	56.5	56.2	60.6	48.2	54.5	54.5	54.5	54.5	58.6	47.3	52.5	52.5	52.5	52.5	NA	NA
9940	24	44.4	40.6	49.6	30.8	57.3	20.0	41.6	38.8	46.8	29.6	54.4	19.1	38.8	37.0	43.9	28.2	NA	NA
	27	48.7	48.7	52.6	41.8	59.0	27.9	46.2	46.2	50.1	40.5	56.4	27.1	43.6	43.6	47.5	39.1	NA	NA
	30	52.9	52.9	55.5	51.0	60.6	39.9	50.6	50.6	53.2	49.7	58.3	39.1	48.4	48.4	50.9	48.4	NA	NA
	33	58.3	58.3	58.3	58.3	62.0	50.3	56.3	56.3	56.3	56.3	60.0	49.4	54.2	54.2	54.2	54.2	NA	NA
10875	24	46.1	42.5	51.0	32.5	58.3	20.4	43.3	40.8	48.2	31.2	55.5	19.4	40.5	39.0	45.3	29.9	NA	NA
	27	50.4	50.4	54.0	43.5	60.0	29.4	47.9	47.9	51.5	42.3	57.5	28.6	45.4	45.4	48.9	40.9	NA	NA
	30	54.6	54.6	56.9	52.9	61.6	41.5	52.4	52.4	54.6	51.6	59.3	40.7	50.1	50.1	52.3	50.3	NA	NA
	33	59.7	59.7	59.7	59.7	63.1	52.0	57.7	57.7	57.7	57.7	61.1	51.1	55.6	55.6	55.6	55.6	NA	NA
11810	24	47.5	44.1	52.0	33.7	59.0	20.7	44.7	42.4	49.2	32.5	56.1	19.6	41.8	40.6	46.3	31.2	NA	NA
	27	51.8	51.8	55.1	44.9	60.7	30.5	49.3	49.3	52.5	43.7	58.1	29.7	46.7	46.7	49.9	42.3	NA	NA
	30	56.0	56.0	58.0	54.5	62.4	42.8	53.8	53.8	55.7	53.2	60.0	42.0	51.5	51.5	53.3	51.8	NA	NA
	33	60.8	60.8	60.8	60.8	63.9	53.3	58.7	58.7	58.7	58.7	61.8	52.5	56.7	56.7	56.7	56.7	NA	NA
12745	24	48.5	45.3	52.7	34.7	59.3	20.8	45.7	43.6	49.8	33.4	56.4	19.8	42.8	41.8	46.9	32.1	NA	NA
	27	52.8	52.8	55.7	46.0	61.1	31.3	50.3	50.3	53.2	44.7	58.5	30.5	47.7	47.7	50.5	43.4	NA	NA
	30	57.1	57.1	58.7	55.6	62.7	43.7	54.8	54.8	56.4	54.3	60.4	42.8	52.5	52.5	54.0	53.0	NA	NA
	33	61.5	61.5	61.5	61.5	64.2	54.4	59.4	59.4	59.4	59.4	62.1	53.5	NA	NA	NA	NA	NA	NA

**Notes:**

1. All capacities shown are gross and have not considered indoor fan heat.
2. TGC = Total gross capacity (kW)
3. SHC = Sensible heat capacity (kW)

**Gross Cooling Capacities**
**Table 11. Gross cooling capacities T/YS\*200FD (IP)**

Airflow CFM	Enter DB (°F)	Ambient Temperature (°F)																	
		85						95						105					
		Entering Wet Bulb Temperature (°F)																	
		61		67		73		61		67		73		61		67		73	
TGC	SHC	TGC	SHC	TGC	SHC	TGC	SHC	TGC	SHC	TGC	SHC	TGC	SHC	TGC	SHC	TGC	SHC		
5300	75	196.1	161.7	216.0	119.8	244.3	85.5	179.6	152.2	199.2	113.5	227.2	79.5	162.3	141.9	181.7	106.4	209.3	73.3
	80	205.2	189.7	220.7	157.1	244.5	101.4	190.6	180.1	205.7	150.7	229.3	98.1	175.1	169.6	190.0	143.4	213.2	94.1
	85	213.9	211.9	224.9	188.7	244.3	142.3	201.1	201.1	211.8	182.1	230.9	138.9	187.5	187.5	197.9	174.7	216.7	134.7
	90	222.1	222.1	228.8	214.5	243.7	177.4	211.2	211.2	217.5	207.8	232.2	173.9	199.4	199.4	205.5	200.3	219.8	169.6
5850	75	203.6	169.5	222.3	126.6	249.4	87.3	187.0	160.0	205.5	120.3	232.2	81.3	169.6	149.6	187.8	113.1	214.2	75.0
	80	212.7	197.9	227.1	164.3	249.7	107.5	198.0	188.3	212.0	157.9	234.4	104.3	182.4	177.8	196.2	150.6	218.2	100.3
	85	221.5	220.5	231.4	196.3	249.6	148.8	208.6	208.6	218.2	189.7	236.1	145.5	194.9	194.9	204.2	182.4	221.8	141.3
	90	229.8	229.8	235.3	222.5	249.0	184.4	218.7	218.7	223.9	215.8	237.4	180.9	206.9	206.9	211.7	208.3	224.9	176.6
6400	75	209.8	176.1	227.4	132.1	253.3	88.7	193.1	166.6	210.4	125.8	236.0	82.6	175.6	156.2	192.6	118.7	217.9	76.3
	80	219.0	204.9	232.2	170.3	253.7	112.5	204.2	195.3	217.0	163.9	238.2	109.3	188.5	184.8	201.1	156.6	221.9	105.3
	85	227.8	227.8	236.6	202.7	253.6	154.2	214.8	214.8	223.2	196.2	240.0	150.9	201.0	201.0	209.1	188.8	225.6	146.7
	90	236.2	236.2	240.5	229.3	253.1	190.2	225.0	225.0	229.0	222.7	241.3	186.8	214.6	213.1	216.8	215.2	228.8	182.5
6950	75	214.9	181.4	231.3	136.5	256.0	89.6	198.1	171.9	214.2	130.2	238.6	83.5	180.4	161.6	196.2	123.1	220.4	77.1
	80	224.1	210.7	236.1	175.1	256.4	116.3	209.2	201.1	220.8	168.7	240.8	113.1	193.4	190.6	204.8	161.4	224.4	109.1
	85	233.0	233.0	240.5	207.9	256.4	158.4	219.8	219.8	227.1	201.4	242.7	155.1	205.9	205.9	212.9	194.0	228.1	151.0
	90	241.4	241.4	244.5	235.0	256.0	194.8	230.1	230.1	232.9	228.3	244.1	191.4	220.6	220.6	220.6	220.6	231.4	187.1
7500	75	218.7	185.6	233.9	139.6	257.5	90.1	201.7	176.1	216.7	133.4	239.9	84.0	184.0	165.8	198.6	126.3	221.6	77.6
	80	228.0	215.3	238.8	178.7	257.9	118.9	212.9	205.7	223.4	172.3	242.2	115.7	197.0	195.2	207.2	165.0	225.7	111.7
	85	236.9	236.9	243.3	211.9	258.0	161.4	223.6	223.6	229.7	205.4	244.1	158.2	209.6	209.6	215.4	198.0	229.5	154.0
	90	245.4	245.4	247.3	239.4	257.6	198.3	234.0	234.0	235.6	232.8	245.6	194.8	223.1	223.1	223.1	223.1	232.8	190.6
Airflow CFM	Enter DB (°F)	Ambient Temperature (°F)																	
		115						120						125					
		Entering Wet Bulb Temperature (°F)																	
		61		67		73		61		67		73		61		67		73	
TGC	SHC	TGC	SHC	TGC	SHC	TGC	SHC	TGC	SHC	TGC	SHC	TGC	SHC	TGC	SHC	TGC	SHC		
5300	75	144.3	130.7	163.3	98.4	190.6	66.7	134.9	124.7	153.8	94.0	180.9	63.3	125.4	118.6	144.1	89.5	NA	NA
	80	158.9	158.3	173.5	135.3	196.4	89.1	150.4	150.4	164.9	130.9	187.6	86.4	141.8	141.8	156.1	126.3	NA	NA
	85	173.1	173.1	183.2	166.5	201.7	129.7	165.6	165.6	175.6	162.0	193.9	126.8	157.9	157.9	167.7	157.4	NA	NA
	90	190.7	190.7	192.6	191.9	206.7	164.4	185.9	185.9	185.9	185.9	199.8	161.5	178.9	178.9	178.9	178.9	NA	NA
5850	75	151.4	138.4	169.3	105.1	195.4	68.4	142.0	132.5	159.7	100.8	185.7	65.0	132.4	126.4	149.9	96.3	NA	NA
	80	166.1	166.1	179.5	142.5	201.2	95.3	157.6	157.6	170.9	138.1	192.4	92.6	148.9	148.9	162.0	133.5	NA	NA
	85	180.3	180.3	189.3	174.1	206.6	136.3	172.8	172.8	181.6	169.7	198.8	133.4	165.0	165.0	173.7	165.0	NA	NA
	90	198.8	198.8	198.8	198.8	211.6	171.5	192.0	192.0	192.0	192.0	204.7	168.6	185.0	185.0	185.0	185.0	NA	NA
6400	75	157.3	145.0	174.0	110.7	199.0	69.6	147.9	139.1	164.4	106.4	189.2	66.2	138.2	133.0	154.6	101.9	NA	NA
	80	172.0	172.0	184.3	148.5	204.9	100.4	163.5	163.5	175.6	144.2	196.0	97.6	154.8	154.8	166.7	139.6	NA	NA
	85	186.4	186.4	194.2	180.6	210.3	141.7	178.8	178.8	186.4	176.1	202.4	138.9	170.9	170.9	178.4	171.5	NA	NA
	90	203.7	203.7	203.7	203.7	215.4	177.3	196.8	196.8	196.8	196.8	208.4	174.4	189.8	189.8	189.8	189.8	NA	NA
6950	75	162.0	150.4	177.5	115.1	201.3	70.5	152.5	144.5	167.8	110.8	191.5	67.0	142.8	138.4	158.0	106.3	NA	NA
	80	176.8	176.8	187.9	153.3	207.3	104.2	168.2	168.2	179.1	149.0	198.4	101.4	159.4	159.4	170.2	144.4	NA	NA
	85	191.2	191.2	197.8	185.8	212.8	146.0	183.5	183.5	190.0	181.4	204.8	143.1	175.6	175.6	182.0	176.7	NA	NA
	90	207.3	207.3	207.3	207.3	217.9	182.0	200.4	200.4	200.4	200.4	210.8	179.1	193.3	193.3	193.3	193.3	NA	NA
7500	75	165.4	154.6	179.8	118.3	202.4	70.9	155.9	148.7	170.1	114.0	192.6	67.4	146.1	142.6	160.1	109.5	NA	NA
	80	180.3	180.3	190.2	157.0	208.4	106.8	171.6	171.6	181.4	152.6	199.5	104.0	162.8	162.8	172.4	148.0	NA	NA
	85	194.7	194.7	200.2	189.8	214.0	149.0	187.0	187.0	192.3	185.4	205.9	146.2	179.0	179.0	184.2	180.8	NA	NA
	90	209.8	209.8	209.8	209.8	219.1	185.4	202.8	202.8	202.8	202.8	212.0	182.6	NA	NA	NA	NA	NA	NA

**Notes:**

1. All capacities shown are gross and have not considered indoor fan heat.
2. TGC = Total gross capacity (kW)
3. SHC = Sensible heat capacity (kW)



**Performance Data**

*Gross Cooling Capacities*

**Table 12. Gross cooling capacities T/YS\*250FD (SI)**

Airflow m <sup>3</sup> /h	Enter DB (°C)	Ambient Temperature (°C)																	
		30						35						40					
		Entering Wet Bulb Temperature (°C)																	
		16		19		22		16		19		22		16		19		22	
TGC	SHC	TGC	SHC	TGC	SHC	TGC	SHC	TGC	SHC	TGC	SHC	TGC	SHC	TGC	SHC	TGC	SHC		
11380	24	66.1	54.9	70.9	39.4	77.7	27.2	61.5	52.4	66.3	38.0	73.0	25.6	56.4	49.4	61.1	36.0	67.7	23.7
	27	68.6	64.1	72.3	52.1	77.9	31.6	64.5	61.4	68.1	50.5	73.7	31.1	59.8	58.2	63.4	48.4	68.9	30.1
	30	70.8	70.8	73.4	62.7	77.9	45.7	67.2	67.2	69.7	60.9	74.1	45.0	63.0	63.0	65.4	58.6	69.9	43.8
	33	72.7	72.7	74.1	71.1	77.5	57.7	69.6	69.6	71.0	69.2	74.3	56.8	66.5	65.9	67.2	66.6	70.5	55.4
12490	24	67.6	56.6	72.1	41.1	78.6	27.5	62.9	54.1	67.4	39.7	73.8	25.8	57.8	51.1	62.2	37.8	68.6	24.0
	27	70.1	65.9	73.5	53.9	78.9	33.4	66.0	63.2	69.3	52.3	74.7	32.9	61.4	60.0	64.6	50.2	69.9	31.9
	30	72.4	72.4	74.7	64.5	78.9	47.6	68.8	68.8	71.0	62.8	75.2	46.9	64.7	64.7	66.8	60.5	70.9	45.7
	33	74.5	74.5	75.6	73.0	78.7	59.6	71.4	71.4	72.4	71.1	75.5	58.8	68.0	68.0	68.7	68.7	71.7	57.4
13590	24	68.8	58.2	73.0	42.7	79.2	27.7	64.2	55.8	68.4	41.4	74.5	26.1	59.1	52.9	63.2	39.5	69.3	24.3
	27	71.5	67.6	74.6	55.6	79.7	35.1	67.4	65.0	70.4	54.1	75.5	34.7	62.8	61.9	65.7	52.0	70.7	33.7
	30	73.9	73.9	75.9	66.3	79.8	49.3	70.3	70.3	72.2	64.6	76.1	48.8	66.2	66.2	68.0	62.4	71.8	47.6
	33	76.1	76.1	76.9	74.9	79.7	61.5	73.0	73.0	73.7	73.0	76.5	60.7	70.0	70.0	70.0	70.0	72.7	59.4
14700	24	69.9	59.8	73.8	44.3	79.7	27.9	65.3	57.5	69.2	43.0	75.1	26.3	60.2	54.6	64.0	41.2	69.8	24.4
	27	72.7	69.3	75.5	57.3	80.3	36.7	68.6	66.7	71.4	55.8	76.1	36.4	64.0	63.6	66.7	53.8	71.4	35.5
	30	75.2	75.2	76.9	68.1	80.5	51.1	71.6	71.6	73.3	66.4	76.9	50.6	67.5	67.5	69.1	64.3	72.6	49.5
	33	77.5	77.5	78.0	76.7	80.5	63.3	74.9	74.9	74.9	74.9	77.3	62.6	71.2	71.2	71.2	71.2	73.6	61.3
15800	24	70.8	61.4	74.5	45.8	80.1	28.0	66.3	59.1	69.9	44.6	75.4	26.4	61.2	56.2	64.7	42.8	70.2	24.6
	27	73.8	70.9	76.3	58.9	80.7	38.4	69.7	68.4	72.1	57.5	76.6	38.1	65.1	65.1	67.5	55.5	71.9	37.2
	30	76.4	76.4	77.8	69.8	81.1	52.8	72.8	72.8	74.1	68.2	77.4	52.3	68.7	68.7	70.0	66.1	73.2	51.3
	33	78.2	78.2	79.0	78.5	81.2	65.1	75.9	75.9	75.9	75.9	78.0	64.4	72.2	72.2	72.2	72.2	74.3	63.2
Airflow m <sup>3</sup> /h	Enter DB (°C)	Ambient Temperature (°C)																	
		45						49						52					
		Entering Wet Bulb Temperature (°C)																	
		16		19		22		16		19		22		16		19		22	
TGC	SHC	TGC	SHC	TGC	SHC	TGC	SHC	TGC	SHC	TGC	SHC	TGC	SHC	TGC	SHC	TGC	SHC		
11380	24	50.6	45.8	55.3	33.5	61.9	21.7	47.6	43.7	52.2	32.0	58.8	20.6	44.4	41.6	49.0	30.4	55.6	19.4
	27	54.6	54.4	58.1	45.7	63.6	28.5	51.8	51.8	55.3	44.1	60.8	27.5	48.8	48.8	52.3	42.4	57.8	26.3
	30	58.3	58.3	60.7	55.7	65.0	42.0	55.7	55.7	58.1	54.1	62.4	40.9	53.0	53.0	55.3	52.3	59.7	39.7
	33	62.9	62.9	62.9	62.9	66.2	53.4	60.6	60.6	60.6	60.6	63.8	52.3	58.1	58.1	58.1	58.1	61.3	50.9
12490	24	52.1	47.6	56.4	35.3	62.8	22.0	49.0	45.6	53.4	33.9	59.7	20.9	45.9	43.5	50.2	32.3	56.4	19.8
	27	56.2	56.2	59.4	47.6	64.6	30.4	53.4	53.4	56.6	46.0	61.7	29.4	50.4	50.4	53.6	44.4	58.7	28.2
	30	60.0	60.0	62.0	57.7	66.1	44.0	57.4	57.4	59.5	56.1	63.5	42.9	54.7	54.7	56.7	54.3	60.8	41.7
	33	64.4	64.4	64.4	64.4	67.4	55.5	62.1	62.1	62.1	62.1	65.0	54.3	59.6	59.6	59.6	59.6	62.5	53.0
13590	24	53.4	49.4	57.5	37.1	63.5	22.2	50.3	47.4	54.4	35.7	60.4	21.1	47.2	45.3	51.2	34.1	57.2	20.0
	27	57.6	57.6	60.5	49.4	65.4	32.2	54.8	54.8	57.7	47.9	62.6	31.2	51.8	51.8	54.7	46.3	59.6	30.1
	30	61.5	61.5	63.3	59.6	67.1	45.9	58.9	58.9	60.7	58.0	64.5	44.9	56.2	56.2	58.0	56.3	61.7	43.7
	33	65.8	65.8	65.8	65.8	68.4	57.5	63.4	63.4	63.4	63.4	66.1	56.4	61.0	61.0	61.0	61.0	63.6	55.1
14700	24	54.5	51.1	58.3	38.8	64.1	22.4	51.5	49.2	55.2	37.4	61.0	21.3	48.3	47.1	52.0	35.9	57.7	20.2
	27	58.8	58.8	61.5	51.2	66.1	34.0	56.0	56.0	58.6	49.8	63.2	33.1	53.1	53.1	55.7	48.1	60.3	32.0
	30	62.8	62.8	64.3	61.5	67.8	47.8	60.3	60.3	61.8	59.9	65.2	46.8	57.6	57.6	59.1	58.2	62.5	45.6
	33	67.0	67.0	67.0	67.0	69.3	59.5	64.6	64.6	64.6	64.6	67.0	58.3	62.2	62.2	62.2	62.2	64.5	57.1
15800	24	55.5	52.8	59.0	40.5	64.5	22.6	52.5	50.9	55.9	39.2	61.4	21.5	49.3	48.8	52.8	37.6	58.2	20.4
	27	59.9	59.9	62.3	53.0	66.6	35.8	57.1	57.1	59.5	51.6	63.8	34.9	54.2	54.2	56.5	50.0	60.8	33.8
	30	64.0	64.0	65.3	63.4	68.5	49.7	61.5	61.5	62.7	61.8	65.9	48.7	60.0	60.0	60.0	60.0	63.2	47.5
	33	68.0	68.0	68.0	68.0	70.0	61.4	65.7	65.7	65.7	65.7	67.7	60.3	63.2	63.2	63.2	63.2	65.2	59.1

**Notes:**

1. All capacities shown are gross and have not considered indoor fan heat.
2. TGC = Total gross capacity (kW)
3. SHC = Sensible heat capacity (kW)

**Gross Cooling Capacities**
**Table 13. Gross cooling capacities T/YS\*250FD (IP)**

Airflow CFM	Enter DB (°F)	Ambient Temperature (°F)																	
		85						95						105					
		Entering Wet Bulb Temperature (°F)																	
		61		67		73		61		67		73		61		67		73	
TGC	SHC	TGC	SHC	TGC	SHC	TGC	SHC	TGC	SHC	TGC	SHC	TGC	SHC	TGC	SHC	TGC	SHC		
6700	75	225.7	187.4	242.0	134.4	265.2	92.8	209.9	178.9	226.1	129.6	249.1	87.2	192.3	168.4	208.3	122.9	231.1	80.9
	80	234.1	218.8	246.6	177.8	265.9	107.9	220.0	209.6	232.4	172.4	251.5	106.2	204.1	198.6	216.3	165.1	235.2	102.6
	85	241.6	241.6	250.3	213.9	265.7	156.0	229.2	229.2	237.7	207.9	252.9	153.7	215.0	215.0	223.3	199.9	238.3	149.5
	90	248.2	248.2	253.0	242.6	264.5	196.8	237.5	237.5	242.1	235.9	253.4	193.9	227.0	224.9	229.3	227.4	240.5	189.0
7350	75	230.5	193.1	245.8	140.1	268.0	93.8	214.7	184.7	230.0	135.4	251.9	88.2	197.2	174.5	212.2	128.9	234.0	81.9
	80	239.3	224.8	250.8	183.8	269.1	113.8	225.3	215.8	236.6	178.5	254.7	112.3	209.4	204.9	220.5	171.4	238.5	108.9
	85	247.2	247.2	254.8	220.2	269.2	162.3	234.8	234.8	242.3	214.3	256.5	160.1	220.6	220.6	227.9	206.5	242.0	156.0
	90	254.1	254.1	257.9	249.1	268.4	203.3	243.5	243.5	247.1	242.6	257.4	200.5	232.0	232.0	234.4	234.2	244.6	195.9
8000	75	234.7	198.7	249.1	145.7	270.3	94.6	219.1	190.5	233.3	141.2	254.3	89.0	201.5	180.4	215.6	134.8	236.4	82.7
	80	243.9	230.6	254.5	189.7	271.8	119.7	230.0	221.8	240.3	184.5	257.4	118.3	214.1	211.1	224.3	177.5	241.2	115.0
	85	252.2	252.2	258.9	226.3	272.3	168.4	239.9	239.9	246.4	220.5	259.6	166.3	225.7	225.7	232.1	212.9	245.1	162.5
	90	259.5	259.5	262.3	255.5	271.9	209.7	248.9	248.9	251.5	249.2	260.9	207.0	238.9	238.9	238.9	238.9	248.1	202.5
8650	75	238.5	204.2	251.9	151.1	272.0	95.2	222.9	196.1	236.1	146.8	256.1	89.6	205.4	186.2	218.4	140.5	238.2	83.4
	80	248.1	236.4	257.6	195.4	273.9	125.4	234.1	227.7	243.5	190.4	259.6	124.1	218.3	217.1	227.5	183.6	243.5	121.0
	85	256.7	256.7	262.4	232.3	274.8	174.3	244.5	244.5	249.9	226.7	262.2	172.5	230.3	230.3	235.7	219.2	247.8	168.7
	90	264.4	264.4	266.2	261.8	274.8	215.9	255.5	255.5	255.5	255.5	263.9	213.4	242.9	242.9	242.9	242.9	251.1	209.1
9300	75	241.7	209.5	254.1	156.4	273.3	95.6	226.1	201.6	238.4	152.2	257.4	90.1	208.7	191.8	220.7	146.2	239.6	83.9
	80	251.7	242.0	260.2	201.0	275.5	130.9	237.8	233.4	246.1	196.1	261.3	129.9	222.0	222.0	230.2	189.5	245.2	126.9
	85	260.7	260.7	265.3	238.1	276.8	180.2	248.5	248.5	253.0	232.7	264.2	178.5	234.4	234.4	238.7	225.4	249.8	174.9
	90	266.9	266.9	269.5	267.9	277.1	222.0	258.9	258.9	258.9	258.9	266.3	219.7	246.3	246.3	246.3	246.3	253.6	215.5
Airflow CFM	Enter DB (°F)	Ambient Temperature (°F)																	
		115						120						125					
		Entering Wet Bulb Temperature (°F)																	
		61		67		73		61		67		73		61		67		73	
TGC	SHC	TGC	SHC	TGC	SHC	TGC	SHC	TGC	SHC	TGC	SHC	TGC	SHC	TGC	SHC	TGC	SHC		
6700	75	172.8	156.1	188.6	114.3	211.3	73.9	162.3	149.2	178.1	109.3	200.7	70.2	151.4	141.9	167.1	103.8	189.6	66.4
	80	186.3	185.6	198.3	155.9	217.0	97.1	176.7	176.7	188.6	150.6	207.3	93.7	166.6	166.6	178.5	144.8	197.0	89.8
	85	198.9	198.9	207.0	190.1	221.9	143.4	190.1	190.1	198.1	184.5	213.0	139.7	180.9	180.9	188.8	178.4	203.6	135.4
	90	214.7	214.7	214.7	214.7	225.8	182.3	206.7	206.7	206.7	206.7	217.7	178.3	198.3	198.3	198.3	198.3	209.1	173.8
7350	75	177.7	162.3	192.6	120.5	214.2	75.0	167.3	155.5	182.1	115.5	203.6	71.3	156.4	148.3	171.1	110.2	192.6	67.4
	80	191.6	191.6	202.6	162.3	220.4	103.5	182.0	182.0	193.0	157.1	210.6	100.2	172.0	172.0	182.8	151.4	200.4	96.4
	85	204.6	204.6	211.7	196.8	225.6	150.1	195.8	195.8	202.9	191.3	216.7	146.5	186.6	186.6	193.6	185.3	207.3	142.3
	90	219.8	219.8	219.8	219.8	229.9	189.3	211.9	211.9	211.9	211.9	221.8	185.3	203.4	203.4	203.4	203.4	213.3	180.9
8000	75	182.1	168.4	196.0	126.5	216.7	75.8	171.8	161.7	185.5	121.7	206.1	72.1	160.9	154.5	174.6	116.4	195.1	68.3
	80	196.4	196.4	206.4	168.7	223.2	109.9	186.9	186.9	196.8	163.5	213.5	106.6	176.9	176.9	186.7	157.9	203.3	102.8
	85	209.7	209.7	215.9	203.4	228.8	156.7	201.0	201.0	207.1	198.0	219.9	153.1	191.9	191.9	197.8	192.1	210.6	149.1
	90	224.4	224.4	224.4	224.4	233.4	196.2	216.4	216.4	216.4	216.4	225.4	192.3	208.0	208.0	208.0	208.0	216.9	187.9
8650	75	186.0	174.3	198.9	132.4	218.6	76.5	175.7	167.7	188.5	127.7	208.0	72.8	164.8	160.6	177.6	122.5	197.0	69.0
	80	200.7	200.7	209.7	174.9	225.5	116.0	191.2	191.2	200.1	169.8	215.8	112.8	181.2	181.2	190.0	164.3	205.6	109.2
	85	214.4	214.4	219.5	209.9	231.4	163.1	205.7	205.7	210.8	204.5	222.6	159.6	196.6	196.6	201.5	198.7	213.3	155.7
	90	228.4	228.4	228.4	228.4	236.5	202.9	220.5	220.5	220.5	220.5	228.5	199.1	212.1	212.1	212.1	212.1	220.0	194.8
9300	75	189.4	180.1	201.3	138.2	219.9	77.0	179.1	173.6	190.9	133.6	209.4	73.3	168.3	166.6	180.0	128.4	198.5	69.5
	80	204.4	204.4	212.4	180.9	227.2	122.1	194.9	194.9	202.9	175.9	217.6	119.0	185.0	185.0	192.8	170.5	207.4	115.4
	85	218.5	218.5	222.7	216.2	233.6	169.5	209.9	209.9	213.9	210.9	224.8	166.1	204.7	204.7	204.7	204.7	215.5	162.2
	90	231.9	231.9	231.9	231.9	239.0	209.5	224.0	224.0	224.0	224.0	231.0	205.8	215.7	215.7	215.7	215.7	222.6	201.6

**Notes:**

1. All capacities shown are gross and have not considered indoor fan heat.
2. TGC = Total gross capacity (kW)
3. SHC = Sensible heat capacity (kW)



**Performance Data**

*Gross Cooling Capacities*

**Table 14. Gross cooling capacities WS\*155ED, ET (SI)**

Airflow m <sup>3</sup> /h	Enter DB (°C)	Ambient Temperature (°C)																	
		30						35						40					
		Entering Wet Bulb Temperature (°C)																	
		16		19		22		16		19		22		16		19		22	
		TGC	SHC	TGC	SHC	TGC	SHC	TGC	SHC	TGC	SHC	TGC	SHC	TGC	SHC	TGC	SHC	TGC	SHC
7650	24	44.4	36.8	47.8	25.6	49.0	12.5	39.5	34.6	46.8	26.1	49.0	14.0	33.5	31.8	43.6	25.3	48.1	14.7
	27	45.7	44.0	47.8	33.0	49.1	19.8	42.1	42.1	47.0	33.5	49.3	21.1	37.6	37.6	43.8	32.6	48.4	22.4
	30	47.2	47.2	48.1	40.3	49.4	27.3	45.7	45.7	47.3	41.0	49.5	28.2	42.5	42.5	44.4	40.0	48.6	29.8
	33	48.5	48.5	48.6	46.3	49.3	34.0	47.9	47.9	48.1	46.7	49.7	35.6	46.3	46.3	46.5	46.4	48.9	37.0
8500	24	45.7	39.4	48.0	26.6	49.2	11.8	41.8	37.4	47.2	27.1	49.4	12.8	35.7	34.5	44.7	26.6	48.5	14.2
	27	46.7	45.8	48.2	34.6	49.4	19.7	44.2	44.2	47.5	35.4	49.6	20.7	40.9	40.9	44.9	34.9	48.8	22.5
	30	48.1	48.1	48.5	41.7	49.6	27.6	47.3	47.3	48.0	43.2	49.8	28.8	44.9	44.9	46.1	43.0	49.0	30.5
	33	49.2	49.2	48.9	47.6	49.8	34.7	48.9	48.9	48.9	48.4	49.8	37.0	47.8	47.8	47.8	47.8	49.3	38.9
9350	24	46.4	41.1	48.3	26.8	49.3	10.7	43.1	39.8	47.7	28.0	49.4	12.5	37.7	37.0	45.5	27.6	48.9	14.3
	27	47.2	46.9	48.2	34.7	49.4	18.4	46.2	46.2	48.0	37.0	49.9	21.3	42.8	42.8	45.9	37.0	49.2	23.1
	30	48.3	48.6	48.8	43.3	49.9	27.8	48.1	48.1	48.4	44.6	50.0	30.3	46.8	46.8	47.1	45.0	49.4	32.3
	33	49.6	49.6	48.9	48.9	50.0	35.0	49.6	49.6	49.4	49.4	50.3	39.2	48.7	48.7	48.7	48.7	49.7	41.0
10200	24	47.1	42.7	48.4	26.6	49.4	9.0	44.5	42.2	48.0	28.5	49.8	12.4	39.6	39.4	46.1	28.7	49.2	13.8
	27	47.9	47.9	48.6	36.1	49.6	18.7	47.2	47.2	48.2	38.1	50.1	22.0	44.3	44.3	46.7	38.9	49.5	23.6
	30	49.0	49.0	48.8	45.0	49.9	27.8	48.8	48.8	48.7	45.9	50.3	31.7	47.6	47.6	47.8	46.6	49.6	33.3
	33	49.8	49.8	49.5	49.5	50.0	36.1	50.1	50.1	50.1	50.1	50.5	40.6	49.4	49.4	49.4	49.4	50.1	42.5
Airflow m <sup>3</sup> /h	Enter DB (°C)	Ambient Temperature (°C)																	
		45																	
		Entering Wet Bulb Temperature (°C)																	
		16		19		22		16		19		22		16		19		22	
		TGC	SHC	TGC	SHC	TGC	SHC	TGC	SHC	TGC	SHC	TGC	SHC	TGC	SHC	TGC	SHC	TGC	SHC
7650	24	28.7	28.7	37.5	22.7	45.9	14.6												
	27	33.3	33.3	38.1	30.4	46.1	22.0												
	30	38.6	38.6	39.6	37.9	46.4	29.6												
	33	43.1	43.1	43.2	43.2	46.6	36.9												
8500	24	30.7	30.7	38.9	24.2	46.5	14.8												
	27	36.0	36.0	39.3	32.6	46.7	22.9												
	30	41.3	41.3	41.8	41.1	47.0	31.3												
	33	45.4	45.4	45.5	45.5	47.3	39.5												
9350	24	32.6	32.6	40.3	25.7	47.0	14.7												
	27	38.3	38.3	40.8	35.0	47.2	23.7												
	30	43.3	43.3	43.6	43.4	47.4	32.9												
	33	46.9	46.9	47.0	47.0	47.7	41.6												
10200	24	34.3	34.3	41.5	27.3	47.3	14.5												
	27	40.1	40.1	42.3	37.4	47.6	24.7												
	30	45.1	45.1	45.2	45.2	47.8	34.6												
	33	47.8	47.8	47.8	47.8	48.4	43.5												

**Notes:**

1. All capacities shown are gross and have not considered indoor fan heat.
2. TGC = Total gross capacity (kW)
3. SHC = Sensible heat capacity (kW)

**Gross Cooling Capacities**
**Table 15. Gross cooling capacities WS\*155ED, ET (IP)**

Airflow m <sup>3</sup> /h	Enter DB (°C)	Ambient Temperature (°C)																	
		30						35						40					
		Entering Wet Bulb Temperature (°C)																	
		16		19		22		16		19		22		16		19		22	
		TGC	SHC	TGC	SHC	TGC	SHC	TGC	SHC	TGC	SHC	TGC	SHC	TGC	SHC	TGC	SHC	TGC	SHC
7650	24	151.6	125.7	163.0	87.3	167.2	42.6	134.7	118.0	159.6	89.1	167.3	47.9	114.5	108.6	148.8	86.3	164.2	50.3
	27	155.8	150.2	163.1	112.5	167.6	67.6	143.7	143.7	160.4	114.2	168.2	72.1	128.3	128.3	149.4	111.1	165.1	76.4
	30	161.0	161.0	164.2	137.3	168.4	93.0	155.9	155.9	161.4	139.8	168.8	96.1	145.0	145.0	151.6	136.6	165.8	101.6
	33	165.3	165.3	165.9	157.8	168.3	115.9	163.5	163.5	164.2	159.2	169.6	121.4	158.1	158.1	158.6	158.2	166.8	126.3
8500	24	156.0	134.3	163.8	90.9	167.8	40.1	142.5	127.7	161.2	92.4	168.4	43.7	121.7	117.6	152.4	90.8	165.5	48.6
	27	159.3	156.3	164.4	117.9	168.7	67.3	150.7	150.7	162.2	120.6	169.2	70.8	139.5	139.5	153.3	119.2	166.6	76.8
	30	164.0	164.0	165.4	142.2	169.3	94.2	161.4	161.4	163.7	147.5	170.0	98.3	153.1	153.1	157.2	146.8	167.3	104.2
	33	167.8	167.8	166.8	162.5	169.9	118.5	166.8	166.8	166.7	165.2	170.0	126.3	163.1	163.1	163.2	163.2	168.2	132.9
9350	24	158.3	140.1	164.6	91.3	168.2	36.6	147.2	135.8	162.7	95.6	168.5	42.7	128.6	126.4	155.1	94.3	167.0	48.9
	27	161.2	159.9	164.5	118.5	168.6	62.9	157.7	157.7	163.6	126.2	170.3	72.8	145.9	145.9	156.7	126.1	167.8	78.9
	30	164.9	165.7	166.6	147.6	170.2	95.0	164.1	164.1	165.2	152.1	170.7	103.3	159.5	159.5	160.8	153.6	168.4	110.2
	33	169.2	169.2	166.8	166.8	170.6	119.4	169.2	169.2	168.7	168.7	171.5	133.7	166.1	166.1	166.2	166.2	169.7	139.7
10200	24	160.6	145.8	165.0	90.9	168.6	30.8	151.9	143.8	163.6	97.2	170.1	42.4	135.1	134.3	157.4	97.9	168.0	46.9
	27	163.4	163.4	165.9	123.0	169.4	63.8	161.0	161.0	164.5	130.0	171.1	75.0	151.1	151.1	159.3	132.6	168.8	80.7
	30	167.0	167.0	166.5	153.6	170.2	94.8	166.4	166.4	166.3	156.5	171.6	108.2	162.5	162.5	163.2	158.9	169.3	113.6
	33	169.9	169.9	169.0	169.0	170.6	123.2	170.9	170.9	170.9	170.9	172.2	138.4	168.5	168.5	168.6	168.6	171.0	144.9
Airflow m <sup>3</sup> /h	Enter DB (°C)	Ambient Temperature (°C)																	
		45						Entering Wet Bulb Temperature (°C)											
		16		19		22		16		19		22		16		19		22	
		TGC	SHC	TGC	SHC	TGC	SHC	TGC	SHC	TGC	SHC	TGC	SHC	TGC	SHC	TGC	SHC	TGC	SHC
7650	24	97.9	97.9	127.9	77.6	156.5	49.9												
	27	113.7	113.7	129.9	103.7	157.4	75.2												
	30	131.6	131.6	135.1	129.4	158.3	100.9												
	33	147.1	147.1	147.3	147.3	159.1	126.0												
8500	24	104.7	104.7	132.8	82.6	158.6	50.6												
	27	122.7	122.7	134.0	111.3	159.3	78.2												
	30	141.0	141.0	142.7	140.1	160.2	106.9												
	33	155.0	155.0	155.4	155.4	161.4	134.9												
9350	24	111.2	111.2	137.4	87.6	160.2	50.2												
	27	130.8	130.8	139.0	119.5	161.0	81.0												
	30	147.9	147.9	148.7	148.0	161.8	112.4												
	33	160.0	160.0	160.3	160.3	162.8	142.1												
10200	24	117.2	117.2	141.7	93.3	161.4	49.4												
	27	136.7	136.7	144.2	127.5	162.3	84.1												
	30	153.7	153.7	154.1	154.1	163.2	118.0												
	33	163.2	163.2	163.1	163.1	165.2	148.4												

**Notes:**

1. All capacities shown are gross and have not considered indoor fan heat.
2. TGC = Total gross capacity (kW)
3. SHC = Sensible heat capacity (kW)



**Performance Data**

*Gross Cooling Capacities*

**Table 16. Gross cooling capacities WS\*200ED, ET (SI)**

Airflow m <sup>3</sup> /h	Enter DB (°C)	Ambient Temperature (°C)																	
		30						35						40					
		Entering Wet Bulb Temperature (°C)																	
		16		19		22		16		19		22		16		19		22	
		TGC	SHC	TGC	SHC	TGC	SHC	TGC	SHC	TGC	SHC	TGC	SHC	TGC	SHC	TGC	SHC	TGC	SHC
10100	24	56.4	47.3	67.8	36.0	74.3	20.5	49.7	44.6	62.9	34.5	71.1	20.2	43.6	42.2	57.0	32.5	66.8	19.5
	27	58.0	57.4	68.2	45.9	75.1	30.6	52.9	52.9	63.4	44.4	71.6	30.2	48.7	48.7	57.4	42.4	67.2	29.5
	30	62.9	62.9	68.9	56.0	76.0	40.9	59.2	59.2	64.3	54.5	72.4	40.5	55.3	55.3	58.2	52.6	67.7	39.6
	33	68.4	68.4	70.0	66.3	76.9	51.2	64.9	64.9	65.8	64.8	73.0	50.8	60.7	60.7	60.8	60.8	68.3	49.8
11220	24	59.1	50.7	69.3	37.3	75.3	19.9	52.4	48.2	65.0	36.0	72.0	19.4	46.1	45.5	58.7	34.2	67.9	18.8
	27	61.0	61.0	69.9	48.4	76.1	30.9	56.8	56.8	65.4	47.1	72.7	30.7	52.4	52.4	59.3	45.2	68.4	30.2
	30	66.9	66.9	70.7	59.6	77.1	42.3	62.6	62.6	66.3	58.3	73.6	42.1	58.5	58.5	60.3	56.6	69.1	41.5
	33	71.5	71.5	72.3	70.8	78.2	53.7	68.1	68.1	68.3	68.2	74.5	53.5	64.3	64.3	64.4	64.4	69.9	52.9
12340	24	61.1	53.9	70.6	38.4	75.7	18.7	55.0	51.6	66.2	37.3	72.7	18.7	48.3	48.2	60.5	35.8	68.7	18.6
	27	63.8	63.8	71.3	50.7	76.9	31.3	59.8	59.8	66.9	49.6	73.6	31.4	55.4	55.4	61.2	48.0	69.4	31.0
	30	69.5	69.5	72.3	63.1	78.0	43.8	65.9	65.9	67.9	62.0	74.5	43.7	61.4	61.4	63.0	60.6	70.2	43.3
	33	74.1	74.1	74.4	74.1	79.2	56.4	70.6	70.6	70.8	70.8	75.7	56.3	66.8	66.8	66.9	66.9	71.2	55.9
13460	24	62.8	57.0	71.6	39.6	76.3	18.3	57.3	54.9	67.3	38.7	73.3	18.5	50.7	50.7	62.1	37.4	69.3	18.2
	27	66.8	66.8	72.5	53.0	77.4	31.8	62.2	62.2	68.0	52.1	74.3	31.9	57.8	57.8	63.0	50.8	70.2	31.8
	30	71.6	71.6	73.7	66.4	78.7	45.3	68.0	68.0	69.4	65.5	75.4	45.4	64.1	64.1	64.6	63.8	71.0	45.2
	33	76.2	76.2	76.3	76.3	80.0	58.7	72.8	72.8	72.9	72.9	76.7	59.0	68.9	68.9	69.0	69.0	72.2	59.0
Airflow m <sup>3</sup> /h	Enter DB (°C)	Ambient Temperature (°C)																	
		45																	
		Entering Wet Bulb Temperature (°C)																	
		16		19		22		16		19		22		16		19		22	
		TGC	SHC	TGC	SHC	TGC	SHC	TGC	SHC	TGC	SHC	TGC	SHC	TGC	SHC	TGC	SHC	TGC	SHC
10100	24	38.3	38.3	50.6	30.4	61.7	18.2												
	27	44.5	44.5	51.1	40.4	62.0	28.2												
	30	51.0	51.0	52.4	50.7	62.4	38.3												
	33	56.5	56.5	56.6	56.6	62.9	48.5												
11220	24	41.0	41.0	52.6	32.2	62.8	18.3												
	27	47.7	47.7	53.1	43.3	63.2	29.2												
	30	54.2	54.2	54.7	54.3	63.7	40.4												
	33	59.9	59.9	60.0	60.0	64.4	51.8												
12340	24	43.2	43.2	54.0	33.9	63.7	17.9												
	27	50.6	50.6	54.7	46.1	64.2	30.3												
	30	56.6	56.6	56.8	56.8	64.8	42.6												
	33	62.5	62.5	62.6	62.6	65.7	55.1												
13460	24	45.6	45.6	55.1	35.5	64.4	17.6												
	27	53.1	53.1	55.9	48.8	65.0	31.1												
	30	59.3	59.3	59.4	59.4	65.7	44.6												
	33	64.5	64.5	64.6	64.6	66.8	58.4												

**Notes:**

1. All capacities shown are gross and have not considered indoor fan heat.
2. TGC = Total gross capacity (kW)
3. SHC = Sensible heat capacity (kW)



Gross Cooling Capacities

Table 17. Gross cooling capacities WS\*200ED, ET (IP)

Airflow CFM	Enter DB (°F)	Ambient Temperature (°F)																	
		85						95						105					
		Entering Wet Bulb Temperature (°F)																	
		61		67		73		61		67		73		61		67		73	
		TGC	SHC	TGC	SHC	TGC	SHC	TGC	SHC	TGC	SHC	TGC	SHC	TGC	SHC	TGC	SHC	TGC	SHC
5950	75	192.6	161.3	231.2	122.7	253.7	69.8	169.6	152.2	214.6	117.5	242.5	68.8	148.6	144.0	194.5	110.8	227.9	66.4
	80	197.9	195.8	232.5	156.5	256.4	104.5	180.6	180.6	216.3	151.4	244.4	102.9	166.2	166.2	196.0	144.8	229.2	100.7
	85	214.5	214.5	235.0	191.1	259.3	139.6	202.0	202.0	219.3	186.1	246.9	138.0	188.6	188.6	198.6	179.4	231.1	135.1
	90	233.2	233.2	238.7	226.2	262.4	174.5	221.5	221.5	224.5	221.1	249.1	173.3	207.0	207.0	207.4	207.4	233.1	169.8
6600	75	201.8	173.1	236.6	127.1	256.8	67.7	178.9	164.4	221.7	122.9	245.6	66.1	157.2	155.3	200.4	116.5	231.6	64.3
	80	208.3	208.1	238.5	165.0	259.7	105.4	193.9	193.9	223.3	160.7	248.1	104.9	178.6	178.6	202.4	154.3	233.4	103.1
	85	228.3	228.3	241.2	203.4	263.2	144.2	213.7	213.7	226.1	199.0	251.1	143.8	199.6	199.6	205.9	193.0	235.8	141.6
	90	243.8	243.8	246.8	241.7	266.9	183.2	232.3	232.3	232.9	232.7	254.1	182.7	219.3	219.3	219.8	219.8	238.6	180.6
7250	75	208.5	183.9	240.9	131.1	258.3	63.7	187.6	176.1	225.8	127.4	248.0	63.9	164.9	164.6	206.3	122.2	234.5	63.5
	80	217.7	217.7	243.1	173.0	262.3	106.7	203.9	203.9	228.1	169.3	251.2	107.1	189.0	189.0	208.9	163.9	236.8	105.8
	85	237.1	237.1	246.7	215.1	266.2	149.4	224.9	224.9	231.5	211.6	254.3	149.1	209.5	209.5	214.9	206.7	239.4	147.8
	90	252.8	252.8	253.7	252.8	270.4	192.3	240.9	240.9	241.5	241.5	258.3	192.1	227.8	227.8	228.2	228.2	242.8	190.7
7900	75	214.3	194.4	244.2	135.0	260.2	62.3	195.5	187.3	229.5	132.1	250.0	63.3	172.9	172.9	212.0	127.7	236.5	62.1
	80	228.0	228.0	247.2	180.8	264.0	108.3	212.4	212.4	232.1	177.7	253.5	108.9	197.2	197.2	214.9	173.2	239.4	108.6
	85	244.4	244.4	251.4	226.6	268.3	154.5	232.0	232.0	236.6	223.6	257.1	154.8	218.8	218.8	220.6	217.8	242.4	154.2
	90	259.9	259.9	260.4	260.4	272.9	200.3	248.4	248.4	248.6	248.6	261.5	201.3	235.2	235.2	235.5	235.5	246.4	201.3
Airflow CFM	Enter DB (°F)	Ambient Temperature (°F)																	
		115																	
		Entering Wet Bulb Temperature (°F)																	
		61		67		73		61		67		73		61		67		73	
		TGC	SHC	TGC	SHC	TGC	SHC	TGC	SHC	TGC	SHC	TGC	SHC	TGC	SHC	TGC	SHC	TGC	SHC
5950	75	130.5	130.5	172.8	103.7	210.4	62.2												
	80	152.0	152.0	174.4	137.7	211.4	96.3												
	85	173.9	173.9	178.7	173.0	212.8	130.6												
	90	192.8	192.8	193.1	193.1	214.8	165.5												
6600	75	139.9	139.9	179.4	109.9	214.3	62.3												
	80	162.7	162.7	181.3	147.7	215.7	99.8												
	85	184.8	184.8	186.6	185.3	217.2	137.9												
	90	204.4	204.4	204.8	204.8	219.6	176.8												
7250	75	147.4	147.4	184.2	115.6	217.2	61.2												
	80	172.5	172.5	186.5	157.3	219.0	103.3												
	85	193.3	193.3	193.9	193.9	221.1	145.3												
	90	213.1	213.1	213.5	213.5	224.0	188.0												
7900	75	155.5	155.5	188.1	121.1	219.7	60.1												
	80	181.1	181.1	190.7	166.6	221.7	106.0												
	85	202.2	202.2	202.8	202.8	224.3	152.3												
	90	219.9	219.9	220.3	220.3	227.8	199.1												

Notes:

1. All capacities shown are gross and have not considered indoor fan heat.
2. TGC = Total gross capacity (kW)
3. SHC = Sensible heat capacity (kW)



Performance Data

Heating Capacities

Table 18. WS\*155ED, ET net heating capacities (kW)—8500 m<sup>3</sup>/h—(SI)

Outdoor Temp (°C) 70% RH	Peak Net Heating (kW) at Indicated Dry Bulb (°C)				Peak Total Power (kW) at Indicated Dry Bulb (°C)			
	15	21	24	27	15	21	24	27
-24	13.8	13.4	13.2	13.0	10.5	11.5	12.0	12.5
-21	15.3	14.9	14.7	14.5	10.7	11.7	12.1	12.7
-18	17.0	16.5	16.3	16.0	10.9	11.8	12.4	12.9
-15	18.6	17.4	17.1	17.3	11.1	12.0	12.5	14.0
-12	20.2	17.8	18.8	18.8	12.0	12.1	12.7	13.7
-9	21.5	20.9	20.5	20.2	11.4	12.4	12.9	13.5
-6	23.4	22.7	22.3	21.9	11.6	12.5	13.1	13.7
-3	25.4	24.6	24.2	23.8	11.8	12.7	13.3	13.9
0	27.4	26.6	26.2	25.8	11.9	13.0	13.5	14.1
3	29.5	28.6	28.2	27.8	12.1	13.2	13.8	14.4
6	36.1	35.1	34.5	34.0	12.2	13.3	13.9	14.5
9	43.8	42.4	41.7	41.0	12.6	13.6	14.2	14.8
12	46.6	45.3	44.5	43.7	12.8	13.9	14.4	15.0
15	49.8	48.3	47.4	46.8	13.1	14.1	14.7	15.3
18	53.2	51.4	50.7	49.8	13.4	14.4	15.0	15.6
21	57.0	55.1	54.0	53.0	13.7	14.8	15.4	16.0
24	60.5	58.6	57.5	56.5	14.1	15.2	15.8	16.4

Notes:

1. For other airflow conditions, see heating capacity correction factor
2. Net Heating Capacity and Power Input include indoor fan heat at nominal cfm and 0.35 inch ESP. To obtain net heating at other conditions, subtract fan heat at this condition and add fan heat at new condition.
3. Heating capacities and powers are integrated to include the effects of defrost in the frost region.

Table 19. WS\*155ED, ET net heating capacities (MBh)—5000 cfm (IP)

Outdoor Temp (°F) 70% RH	Peak Net Heating (MBh) at Indicated Dry Bulb (°F)				Peak Total Power (kW) at Indicated Dry Bulb (°F)			
	60	70	75	80	60	70	75	80
-8	46.9	45.7	45.0	44.4	10.5	11.5	12.0	12.5
-3	52.4	51.0	50.2	49.5	10.7	11.7	12.1	12.7
2	57.9	56.3	55.5	54.7	10.9	11.8	12.4	12.9
7	63.5	59.2	58.2	59.0	11.1	12.0	12.5	14.0
12	69.0	60.9	64.1	64.1	12.0	12.1	12.7	13.7
17	73.5	71.2	70.0	68.9	11.4	12.4	12.9	13.5
22	79.9	77.3	76.1	74.9	11.6	12.5	13.1	13.7
27	86.5	83.8	82.4	81.1	11.8	12.7	13.3	13.9
32	93.6	90.8	89.2	87.9	11.9	13.0	13.5	14.1
37	100.6	97.5	96.2	94.7	12.1	13.2	13.8	14.4
42	123.3	119.7	117.8	116.0	12.2	13.3	13.9	14.5
47	149.3	144.8	142.4	140.0	12.6	13.6	14.2	14.8
52	159.0	154.4	151.9	149.2	12.8	13.9	14.4	15.0
57	170.0	164.7	161.8	159.6	13.1	14.1	14.7	15.3
62	181.5	175.5	172.9	169.7	13.4	14.4	15.0	15.6
67	194.6	187.9	184.2	180.8	13.7	14.8	15.4	16.0
72	206.5	199.8	196.2	192.6	14.1	15.2	15.8	16.4

Notes:

1. For other airflow conditions, see heating capacity correction factor
2. Net Heating Capacity and Power Input include indoor fan heat at nominal cfm and 0.35 inch ESP. To obtain net heating at other conditions, subtract fan heat at this condition and add fan heat at new condition.
3. Heating capacities and powers are integrated to include the effects of defrost in the frost region.

**Heating Capacities**
**Table 20. WS\*200ED, ET net heating capacities (kW) – 11210 m<sup>3</sup>/h – (SI)**

Outdoor Temp (°C) 70% RH	Peak Net Heating (kW) at Indicated Dry Bulb (°C)				Peak Total Power (kW) at Indicated Dry Bulb (°C)			
	15	21	24	27	15	21	24	27
-24	21.3	20.7	20.5	20.3	15.1	15.9	16.4	16.9
-21	23.1	22.5	22.3	22.0	15.3	16.0	16.5	17.0
-18	25.4	24.8	24.5	24.2	15.4	16.2	16.7	17.2
-15	28.0	27.2	27.0	26.6	15.5	16.3	16.8	17.3
-12	31.2	30.7	30.5	30.3	15.7	16.5	17.0	17.5
-9	34.6	33.8	33.6	33.3	15.9	16.7	17.2	17.7
-6	37.7	37.0	36.6	36.2	16.1	16.9	17.4	17.9
-3	40.7	39.9	39.6	39.2	16.4	17.3	17.8	18.3
0	43.7	42.8	42.5	42.1	16.5	17.4	17.9	18.4
3	47.7	46.8	46.3	46.0	16.8	17.7	18.2	18.7
6	51.8	50.6	50.1	49.6	17.0	17.9	18.4	18.9
9	56.3	55.2	54.6	54.2	17.1	18.0	18.5	19.0
12	60.4	59.1	58.4	58.0	17.4	18.3	18.8	19.3
15	64.2	62.7	62.1	61.5	17.8	18.8	19.3	19.8
18	69.1	67.5	66.6	65.9	20.0	21.1	21.6	22.1
21	73.8	71.8	70.9	70.0	20.1	21.2	21.7	22.2
24	78.7	76.8	75.9	74.9	20.4	21.5	22.0	22.6

**Notes:**

1. For other airflow conditions, see heating capacity correction factor
2. Net Heating Capacity and Power Input include indoor fan heat at nominal cfm and 0.35 inch ESP. To obtain net heating at other conditions, subtract fan heat at this condition and add fan heat at new condition.
3. Heating capacities and powers are integrated to include the effects of defrost in the frost region.

**Table 21. WS\*200ED, ET net heating capacities (MBh) – 6600 cfm (IP)**

Outdoor Temp (°F) 70% RH	Peak Net Heating (MBh) at Indicated Dry Bulb (°F)				Peak Total Power (kW) at Indicated Dry Bulb (°F)			
	60	70	75	80	60	70	75	80
-8	72.5	70.6	69.8	69.1	15.1	15.9	16.4	16.9
-3	78.8	76.8	76.1	75.1	15.3	16.0	16.5	17.0
2	86.7	84.5	83.5	82.5	15.4	16.2	16.7	17.2
7	95.4	92.9	92.1	90.9	15.5	16.3	16.8	17.3
12	106.5	104.6	104.0	103.2	15.7	16.5	17.0	17.5
17	118.0	115.4	114.7	113.7	15.9	16.7	17.2	17.7
22	128.6	126.3	124.9	123.5	16.1	16.9	17.4	17.9
27	138.7	136.2	135.0	133.7	16.4	17.3	17.8	18.3
32	149.0	146.2	145.1	143.6	16.5	17.4	17.9	18.4
37	162.8	159.8	158.1	157.1	16.8	17.7	18.2	18.7
42	176.9	172.7	170.8	169.4	17.0	17.9	18.4	18.9
47	192.0	188.2	186.3	184.9	17.1	18.0	18.5	19.0
52	206.0	201.8	199.3	197.8	17.4	18.3	18.8	19.3
57	219.1	213.9	212.0	209.7	17.8	18.8	19.3	19.8
62	235.7	230.1	227.3	225.0	20.0	21.1	21.6	22.1
67	251.6	244.8	242.0	238.8	20.1	21.2	21.7	22.2
72	268.7	262.0	259.1	255.4	20.4	21.5	22.0	22.6

**Notes:**

1. For other airflow conditions, see heating capacity correction factor
2. Net Heating Capacity and Power Input include indoor fan heat at nominal cfm and 0.35 inch ESP. To obtain net heating at other conditions, subtract fan heat at this condition and add fan heat at new condition.
3. Heating capacities and powers are integrated to include the effects of defrost in the frost region.



**Performance Data**

*Fan Performance*

**Table 22. Evaporator fan performance TS\*155F downflow or horizontal (SI)**

External Static Pressure (Pascals)																				
25.00		50.00		75.00		100.00		125.00		150.00		175.00		200.00		225.00		250.00		
m <sup>3</sup> /h	RPM	kW	RPM	kW	RPM	kW	RPM	kW	RPM	kW	RPM	kW	RPM	kW	RPM	kW	RPM	kW	RPM	kW
1.49 Nom kW Standard Motor & Low Static Drive Accessory										1.49 Nom kW Standard Motor & High Static Drive Accessory										
7140	—	—	393	0.46	430	0.54	467	0.64	503	0.74	536	0.84	570	0.95	601	1.06	630	1.18	659	1.31
7820	376	0.48	416	0.58	451	0.66	484	0.75	518	0.86	551	0.97	581	1.08	612	1.20	642	1.32	669	1.45
8500	400	0.60	440	0.70	473	0.80	504	0.89	534	1.00	566	1.12	597	1.24	625	1.35	653	1.48	681	1.61
9180	425	0.73	464	0.85	496	0.96	525	1.06	554	1.16	582	1.28	611	1.41	640	1.54	666	1.66	692	1.79
9860	450	0.89	488	1.01	520	1.14	548	1.24	575	1.35	601	1.47	627	1.59	654	1.73	681	1.87	707	2.01
1.49 Nom kW Standard Motor Drive										2.24 Nom kW Oversized Motor & Drive										

Continued

External Static Pressure (Pascals)																				
275.00		300.00		325.00		350.00		375.00		400.00		425.00		450.00		475.00		500.00		
m <sup>3</sup> /h	RPM	kW	RPM	kW	RPM	kW	RPM	kW	RPM	kW	RPM	kW	RPM	kW	RPM	kW	RPM	kW	RPM	kW
1.49 Nom kW Standard Motor & High Static Drive Accessory									2.24 Nom kW Oversized Motor & Drive											
7140	686	1.44	713	1.56	738	1.69	763	1.82	786	1.95	809	2.08	831	2.21	852	2.34	—	—	—	—
7820	696	1.58	722	1.72	747	1.86	771	2.00	795	2.14	818	2.28	840	2.42	—	—	—	—	—	—
8500	707	1.75	732	1.88	757	2.03	780	2.18	804	2.33	826	2.49	—	—	—	—	—	—	—	—
9180	718	1.93	744	2.08	768	2.22	791	2.37	813	2.53	—	—	—	—	—	—	—	—	—	—
9860	730	2.14	754	2.29	779	2.44	—	—	—	—	—	—	—	—	—	—	—	—	—	—

Note: Data includes pressure drop for filters and wet coil.

**Table 23. Evaporator fan performance TS\*155F downflow or horizontal (IP)**

External Static Pressure (Inches of Water Pressure)																				
.10		.20		.30		.40		.50		.60		.70		.80		.90		1.00		
CFM	RPM	BHP	RPM	BHP	RPM	BHP	RPM	BHP	RPM	BHP	RPM	BHP	RPM	BHP	RPM	BHP	RPM	BHP	RPM	BHP
2HP Standard Motor & Low Static Drive Accessory										2HP Standard Motor & High Static Drive Accessory										
4000	—	—	382	0.56	420	0.66	459	0.79	496	0.91	531	1.05	564	1.19	595	1.34	625	1.50	654	1.67
4500	—	—	410	0.73	446	0.85	479	0.97	514	1.11	548	1.26	578	1.40	610	1.56	639	1.72	666	1.89
5000	400	0.80	440	0.95	473	1.07	504	1.20	534	1.34	566	1.50	597	1.66	625	1.81	653	1.98	681	2.16
5500	431	1.03	470	1.19	502	1.34	531	1.48	559	1.62	586	1.77	615	1.95	643	2.12	670	2.30	695	2.47
6000	463	1.30	500	1.48	531	1.65	559	1.80	585	1.95	611	2.11	636	2.28	662	2.46	689	2.66	714	2.85
2HP Standard Motor Drive										3HP Oversized Motor & Drive										

Continued

External Static Pressure (Inches of Water Pressure)																				
1.10		1.20		1.30		1.40		1.50		1.60		1.70		1.80		1.90		2.00		
CFM	RPM	BHP	RPM	BHP	RPM	BHP	RPM	BHP	RPM	BHP	RPM	BHP	RPM	BHP	RPM	BHP	RPM	BHP	RPM	BHP
2HP Standard Motor & High Static Drive Accessory										3HP Oversized Motor & Drive										
4000	682	1.83	708	1.99	734	2.16	758	2.32	782	2.49	804	2.66	826	2.83	847	3.01	—	—	—	—
4500	693	2.07	719	2.25	745	2.44	769	2.62	793	2.80	815	2.99	838	3.17	—	—	—	—	—	—
5000	707	2.34	732	2.53	757	2.72	780	2.92	804	3.13	826	3.33	—	—	—	—	—	—	—	—
5500	721	2.66	747	2.86	771	3.05	794	3.26	—	—	—	—	—	—	—	—	—	—	—	—
6000	738	3.04	760	3.22	784	3.43	—	—	—	—	—	—	—	—	—	—	—	—	—	—

Note: Data includes pressure drop for filters and wet coil.

## Performance Data

### Fan Performance

**Table 24. Evaporator fan performance TS\*175F downflow or horizontal (SI)**

External Static Pressure (Pascals)																							
		25.00		50.00		75.00		100.00		125.00		150.00		175.00		200.00		225.00		250.00			
m <sup>3</sup> /h	RPM	kW	RPM	kW	RPM	kW	RPM	kW	RPM	kW	RPM	kW	RPM	kW	RPM	kW	RPM	kW	RPM	kW	RPM	kW	
2.24 Nom kw Standard Motor & Low Static Drive Accessory									2.24 Nom kw Standard Motor Drive														
7985	—	—	429	0.62	463	0.71	496	0.81	529	0.92	562	1.03	592	1.14	622	1.26	652	1.39	679	1.52			
8750	419	0.67	457	0.78	489	0.88	520	0.98	549	1.09	580	1.21	610	1.33	638	1.45	665	1.58	693	1.72			
9515	449	0.84	485	0.96	516	1.07	545	1.18	572	1.29	599	1.41	628	1.54	656	1.68	682	1.81	707	1.94			
10280	478	1.04	513	1.17	544	1.30	571	1.41	597	1.52	623	1.64	648	1.77	674	1.92	700	2.07	725	2.21			
11045	508	1.26	542	1.40	572	1.55	598	1.67	623	1.79	647	1.92	671	2.05	694	2.19	718	2.34	743	2.50			
2.24 Nom kw Standard Motor & High Static Drive Accessory																							

Continued

External Static Pressure (Pascals)																							
		275.00		300.00		325.00		350.00		375.00		400.00		425.00		450.00		475.00		500.00			
m <sup>3</sup> /h	RPM	kW	RPM	kW	RPM	kW	RPM	kW	RPM	kW	RPM	kW	RPM	kW	RPM	kW	RPM	kW	RPM	kW	RPM	kW	
2.24 Nom kw Standard Motor & High Static Drive Accessory																							
7985	705	1.65	731	1.79	756	1.94	780	2.09	803	2.23	826	2.37	848	2.52	870	2.66	890	2.81	910	2.95			
8750	719	1.86	744	2.00	768	2.14	792	2.30	815	2.45	837	2.61	859	2.77	880	2.93	901	3.09	921	3.25			
9515	732	2.08	758	2.23	782	2.39	805	2.54	827	2.70	849	2.86	870	3.03	891	3.20	912	3.37	932	3.55			
10280	749	2.35	771	2.49	795	2.65	819	2.82	841	2.98	862	3.15	883	3.31	903	3.49	923	3.67	943	3.85			
11045	767	2.66	789	2.81	811	2.96	832	3.12	854	3.29	876	3.46	897	3.64	917	3.82	937	4.00	956	4.18			
3.73 Nom Oversized Motor & Drive									3.73 Nom Oversized Motor & High Static Drive Accessory														

Note: Data includes pressure drop for filters and wet coil.

**Table 25. Evaporator fan performance TS\*175F downflow or horizontal (IP)**

External Static Pressure (Inches of Water)																							
		.10		.20		.30		.40		.50		.60		.70		.80		.90		1.00			
cfm	RPM	BHP	RPM	BHP	RPM	BHP	RPM	BHP	RPM	BHP	RPM	BHP	RPM	BHP	RPM	BHP	RPM	BHP	RPM	BHP	RPM	BHP	
3HP Standard Motor & Low Static Drive Accessory									3HP Standard Motor Drive														
4700	—	—	429	0.84	463	0.96	496	1.08	529	1.23	562	1.38	592	1.53	622	1.69	652	1.86	679	2.04			
5150	419	0.90	457	1.05	489	1.18	520	1.31	549	1.46	580	1.62	610	1.79	638	1.95	665	2.12	693	2.30			
5600	449	1.13	485	1.29	516	1.44	545	1.58	572	1.73	599	1.88	628	2.07	656	2.25	682	2.43	707	2.60			
6050	478	1.39	513	1.56	544	1.74	571	1.89	597	2.04	623	2.20	648	2.38	674	2.57	700	2.77	725	2.96			
6500	508	1.69	542	1.88	572	2.07	598	2.24	623	2.40	647	2.57	671	2.75	694	2.93	718	3.14	743	3.35			
3HP Standard Motor & High Static Drive Accessory																							

Continued

External Static Pressure (Inches of Water)																							
		1.10		1.20		1.30		1.40		1.50		1.60		1.70		1.80		1.90		2.00			
cfm	RPM	BHP	RPM	BHP	RPM	BHP	RPM	BHP	RPM	BHP	RPM	BHP	RPM	BHP	RPM	BHP	RPM	BHP	RPM	BHP	RPM	BHP	
3HP Standard Motor & High Static Drive Accessory																							
4700	705	2.22	731	2.41	756	2.60	780	2.80	803	2.99	826	3.18	848	3.37	870	3.57	890	3.76	910	3.96			
5150	719	2.49	744	2.68	768	2.88	792	3.08	815	3.29	837	3.51	859	3.72	880	3.93	901	4.14	921	4.35			
5600	732	2.79	758	3.00	782	3.20	805	3.41	827	3.62	849	3.84	870	4.06	891	4.29	912	4.53	932	4.76			
6050	749	3.15	771	3.34	795	3.56	819	3.78	841	4.00	862	4.22	883	4.44	903	4.68	923	4.92	943	5.16			
6500	767	3.56	789	3.77	811	3.97	832	4.18	854	4.41	876	4.65	897	4.88	917	5.12	937	5.36	956	5.61			
5HP Oversized Motor & Drive									5HP Oversized Motor & High Static Drive Accessory														

Note: Data includes pressure drop for filters and wet coil.



**Performance Data**

*Fan Performance*

**Table 26. Evaporator fan performance TS\*200F downflow or horizontal (SI)**

External Static Pressure (Pascals)																				
25.00		50.00		75.00		100.00		125.00		150.00		175.00		200.00		225.00		250.00		
m <sup>3</sup> /h	RPM	kW	RPM	kW	RPM	kW	RPM	kW	RPM	kW	RPM	kW	RPM	kW	RPM	kW	RPM	kW	RPM	kW
<b>2.24 Nom kw Standard Motor &amp; Low Static Drive Accy</b>										<b>2.24 Nom kw Standard Motor &amp; High Static Drive Accy</b>										
9005	429	0.72	466	0.84	498	0.94	528	1.04	557	1.15	586	1.27	616	1.40	644	1.53	670	1.65	697	1.78
9940	465	0.94	501	1.07	531	1.19	559	1.30	586	1.42	612	1.53	638	1.66	666	1.81	692	1.95	717	2.09
10875	502	1.21	536	1.35	565	1.49	592	1.61	617	1.73	642	1.86	665	1.98	689	2.12	714	2.28	739	2.43
11810	539	1.53	572	1.67	600	1.83	626	1.97	650	2.10	673	2.23	695	2.36	717	2.50	739	2.65	761	2.81
12745	575	1.87	607	2.05	635	2.21	660	2.37	683	2.52	704	2.66	726	2.80	747	2.95	767	3.10	787	3.25
<b>2.24 Nom kw Standard Motor Drive</b>										<b>3.73 Nom kw Oversized Motor &amp; Drive</b>										

**Note:** Data includes pressure drop for filters and wet coil.

**Table 27. Evaporator fan performance TS\*200F downflow or horizontal (IP)**

External Static Pressure (Inches of Water)																				
.10		.20		.30		.40		.50		.60		.70		.80		.90		1.00		
cfm	RPM	BHP	RPM	BHP	RPM	BHP	RPM	BHP	RPM	BHP	RPM	BHP	RPM	BHP	RPM	BHP	RPM	BHP	RPM	BHP
<b>3HP Standard Motor &amp; Low Static Drive Accessory</b>										<b>3HP Standard Motor &amp; High Static Drive Accessory</b>										
5300	429	0.97	466	1.13	498	1.26	528	1.40	557	1.54	586	1.70	616	1.88	644	2.05	670	2.21	697	2.39
5850	465	1.27	501	1.44	531	1.60	559	1.75	586	1.90	612	2.06	638	2.23	666	2.42	692	2.61	717	2.80
6400	502	1.62	536	1.81	565	2.00	592	2.16	617	2.32	642	2.49	665	2.66	689	2.85	714	3.05	739	3.26
6950	539	2.05	572	2.24	600	2.45	626	2.64	650	2.82	673	2.99	695	3.17	717	3.36	739	3.55	761	3.77
7500	575	2.51	607	2.74	635	2.97	660	3.18	683	3.38	704	3.57	726	3.76	747	3.95	767	4.16	787	4.36
<b>3HP Standard Motor Drive</b>										<b>5HP Oversized Motor &amp; Drive</b>										

External Static Pressure (Inches of Water)																				
1.10		1.20		1.30		1.40		1.50		1.60		1.70		1.80		1.90		2.00		
cfm	RPM	BHP	RPM	BHP	RPM	BHP	RPM	BHP	RPM	BHP	RPM	BHP	RPM	BHP	RPM	BHP	RPM	BHP	RPM	BHP
<b>3HP Standard Motor &amp; High Static Drive Accessory</b>										<b>5HP Oversized Motor &amp; High Static Drive Accessory</b>										
5300	724	2.59	749	2.78	772	2.98	796	3.18	818	3.40	841	3.61	862	3.83	884	4.05	904	4.27	925	4.48
5850	741	2.98	765	3.18	790	3.40	813	3.61	835	3.82	856	4.04	877	4.27	898	4.50	918	4.74	938	4.98
6400	763	3.47	786	3.67	807	3.87	829	4.08	851	4.31	873	4.55	894	4.78	914	5.01	934	5.26	953	5.50
6950	784	4.00	807	4.23	829	4.45	850	4.67	870	4.89	889	5.11	910	5.35	931	5.60	—	—	—	—
7500	808	4.59	829	4.82	850	5.07	871	5.31	892	5.56	—	—	—	—	—	—	—	—	—	—
<b>5HP Oversized Motor &amp; Drive</b>										<b>5HP Oversized Motor &amp; High Static Drive Accessory</b>										

**Note:** Data includes pressure drop for filters and wet coil.

Fan Performance

**Table 28. Evaporator fan performance TS\*250F downflow or horizontal (SI)**

External Static Pressure (Pascals)																				
	25.00		50.00		75.00		100.00		125.00		150.00		175.00		200.00		225.00		250.00	
m <sup>3</sup> /h	RPM	kW	RPM	kW	RPM	kW	RPM	kW	RPM	kW	RPM	kW	RPM	kW	RPM	kW	RPM	kW	RPM	kW
3.73 Nom kW Standard Motor & Low Static Drive Accessory										3.73 Nom kW Standard Motor and Drive										
11380	521	1.37	556	1.52	584	1.67	610	1.80	635	1.93	658	2.05	681	2.19	704	2.32	727	2.47	751	2.63
12485	566	1.78	597	1.94	625	2.11	650	2.26	674	2.41	696	2.54	717	2.68	738	2.82	759	2.97	780	3.13
13590	610	2.26	639	2.43	667	2.61	691	2.79	714	2.96	735	3.11	755	3.26	775	3.41	795	3.56	814	3.72
14695	656	2.84	683	3.02	709	3.20	732	3.40	754	3.58	775	3.76	794	3.93	813	4.09	832	4.25	—	—
15800	701	3.51	725	3.68	750	3.88	773	4.09	—	—	—	—	—	—	—	—	—	—	—	—

3.73 Nom kW Standard Motor & High Static Drive Accessory (1)

Continued

External Static Pressure (Pascals)																				
	275.00		300.00		325.00		350.00		375.00		400.00		425.00		450.00		475.00		500.00	
m <sup>3</sup> /h	RPM	kW	RPM	kW	RPM	kW	RPM	kW	RPM	kW	RPM	kW	RPM	kW	RPM	kW	RPM	kW	RPM	kW
3.73 Nom kW Standard Motor & High Static Drive Accessory (1)																				
11380	774	2.80	797	2.96	819	3.12	839	3.27	860	3.44	882	3.61	903	3.79	924	3.98	943	4.16	—	—
12485	801	3.29	823	3.47	844	3.65	865	3.83	886	4.01	905	4.18	—	—	—	—	—	—	—	—
13590	833	3.88	852	4.06	871	4.24	—	—	—	—	—	—	—	—	—	—	—	—	—	—
14695	—	—	—	—	—	—	—	—	—	—	—	—	—	—	—	—	—	—	—	—
15800	—	—	—	—	—	—	—	—	—	—	—	—	—	—	—	—	—	—	—	—

3.73 Nom kW Standard Motor & High Static Drive Accessory (2)

Note: Data includes pressure drop for filters and wet coil.

**Table 29. Evaporator fan performance TS\*250F downflow or horizontal (IP)**

External Static Pressure (Inches of Water)																				
	.10		.20		.30		.40		.50		.60		.70		.80		.90		1.00	
cfm	RPM	BHP	RPM	BHP	RPM	BHP	RPM	BHP	RPM	BHP	RPM	BHP	RPM	BHP	RPM	BHP	RPM	BHP	RPM	BHP
5HP Standard Motor & Low Static Drive Accessory										5HP Standard Motor and Drive										
6700	521	1.84	556	2.04	584	2.23	610	2.42	635	2.58	658	2.75	681	2.93	704	3.11	727	3.31	751	3.53
7350	566	2.39	597	2.60	625	2.82	650	3.03	674	3.23	696	3.40	717	3.59	738	3.78	759	3.98	780	4.19
8000	610	3.03	639	3.26	667	3.50	691	3.74	714	3.97	735	4.17	755	4.37	775	4.57	795	4.78	814	4.99
8650	656	3.81	683	4.06	709	4.30	732	4.56	754	4.80	775	5.05	794	5.27	813	5.48	832	5.70	—	—
9300	701	4.70	725	4.93	750	5.20	773	5.48	—	—	—	—	—	—	—	—	—	—	—	—

5HP Standard Motor & High Static Drive Accessory (1)

Continued

External Static Pressure (Inches of Water)																				
	1.10		1.20		1.30		1.40		1.50		1.60		1.70		1.80		1.90		2.00	
cfm	RPM	BHP	RPM	BHP	RPM	BHP	RPM	BHP	RPM	BHP	RPM	BHP	RPM	BHP	RPM	BHP	RPM	BHP	RPM	BHP
5HP Standard Motor & High Static Drive Accessory (1)																				
6700	774	3.75	797	3.97	819	4.18	839	4.39	860	4.61	882	4.84	903	5.09	924	5.33	943	5.58	—	—
7350	801	4.42	823	4.66	844	4.90	865	5.13	886	5.37	905	5.60	—	—	—	—	—	—	—	—
8000	833	5.21	852	5.44	871	5.69	—	—	—	—	—	—	—	—	—	—	—	—	—	—
8650	—	—	—	—	—	—	—	—	—	—	—	—	—	—	—	—	—	—	—	—
9300	—	—	—	—	—	—	—	—	—	—	—	—	—	—	—	—	—	—	—	—

5HP Standard Motor & High Static Drive Accessory (2)

Note: Data includes pressure drop for filters and wet coil.



**Performance Data**

*Fan Performance*

**Table 30. Evaporator fan performance YS\*155F downflow or horizontal (SI)**

External Static Pressure (Pascals)																				
25.00		50.00		75.00		100.00		125.00		150.00		175.00		200.00		225.00		250.00		
m <sup>3</sup> /h	RPM	kW	RPM	kW	RPM	kW	RPM	kW	RPM	kW	RPM	kW	RPM	kW	RPM	kW	RPM	kW	RPM	kW
1.49 Nom kW Standard Motor & Low Static Drive Accessory											1.49 Nom kW Standard Motor & High Static Drive Accessory									
7140	—	—	404	0.49	441	0.57	478	0.67	514	0.77	547	0.87	580	0.98	610	1.10	639	1.22	667	1.35
7820	391	0.52	429	0.61	463	0.69	496	0.79	530	0.90	563	1.01	593	1.12	624	1.24	652	1.37	679	1.49
8500	418	0.64	455	0.75	487	0.84	517	0.94	548	1.05	579	1.17	609	1.29	636	1.40	665	1.53	692	1.67
9180	446	0.79	481	0.91	511	1.01	540	1.11	568	1.22	596	1.34	626	1.47	653	1.60	679	1.73	705	1.86
9860	473	0.96	507	1.09	536	1.20	564	1.31	590	1.42	616	1.54	643	1.67	670	1.81	696	1.95	720	2.09
1.49 Nom kW Standard Motor Drive											2.24 Nom kW Oversized Motor & Drive									

Continued

External Static Pressure (Pascals)																				
275.00		300.00		325.00		350.00		375.00		400.00		425.00		450.00		475.00		500.00		
m <sup>3</sup> /h	RPM	kW	RPM	kW	RPM	kW	RPM	kW	RPM	kW	RPM	kW	RPM	kW	RPM	kW	RPM	kW	RPM	kW
1.49 Nom kW Standard Motor & High Static Drive Accessory											2.24 Nom kW Oversized Motor & Drive									
7140	694	1.48	721	1.60	746	1.73	770	1.86	793	1.99	816	2.12	837	2.25	859	2.38	—	—	—	—
7820	705	1.63	731	1.77	756	1.91	780	2.05	803	2.19	826	2.33	848	2.47	—	—	—	—	—	—
8500	718	1.80	743	1.95	767	2.09	790	2.24	813	2.40	836	2.55	—	—	—	—	—	—	—	—
9180	732	2.01	756	2.15	779	2.30	802	2.45	—	—	—	—	—	—	—	—	—	—	—	—
9860	744	2.22	769	2.38	793	2.53	—	—	—	—	—	—	—	—	—	—	—	—	—	—

Note: Data includes pressure drop for filters and wet coil.

**Table 31. Evaporator fan performance YS\*155F downflow or horizontal (IP)**

External Static Pressure (Inches of Water)																				
.10		.20		.30		.40		.50		.60		.70		.80		.90		1.00		
CFM	RPM	BHP	RPM	BHP	RPM	BHP	RPM	BHP	RPM	BHP	RPM	BHP	RPM	BHP	RPM	BHP	RPM	BHP	RPM	BHP
2HP Standard Motor & Low Static Drive Accessory											2HP Standard Motor & High Static Drive Accessory									
4200	—	—	404	0.65	441	0.77	478	0.90	514	1.03	547	1.17	580	1.32	610	1.47	639	1.63	667	1.80
4600	391	0.69	429	0.81	463	0.93	496	1.06	530	1.21	563	1.36	593	1.50	624	1.67	652	1.83	679	2.00
5000	418	0.86	455	1.00	487	1.13	517	1.26	548	1.41	579	1.57	609	1.73	636	1.88	665	2.06	692	2.24
5400	446	1.06	481	1.22	511	1.35	540	1.49	568	1.63	596	1.80	626	1.97	653	2.15	679	2.31	705	2.49
5800	473	1.28	507	1.46	536	1.61	564	1.75	590	1.90	616	2.06	643	2.24	670	2.43	696	2.62	720	2.80
2HP Standard Motor Drive											3HP Oversized Motor & Drive									

Continued

External Static Pressure (Inches of Water)																				
1.10		1.20		1.30		1.40		1.50		1.60		1.70		1.80		1.90		2.00		
CFM	RPM	BHP	RPM	BHP	RPM	BHP	RPM	BHP	RPM	BHP	RPM	BHP	RPM	BHP	RPM	BHP	RPM	BHP	RPM	BHP
2HP Standard Motor & High Static Drive Accessory											3HP Oversized Motor & Drive									
4200	694	1.98	721	2.15	746	2.32	770	2.49	793	2.67	816	2.84	837	3.02	859	3.20	—	—	—	—
4600	705	2.18	731	2.37	756	2.56	780	2.75	803	2.94	826	3.12	848	3.31	—	—	—	—	—	—
5000	718	2.42	743	2.61	767	2.81	790	3.01	813	3.22	836	3.42	—	—	—	—	—	—	—	—
5400	732	2.69	756	2.88	779	3.08	802	3.29	—	—	—	—	—	—	—	—	—	—	—	—
5800	744	2.98	769	3.19	793	3.40	—	—	—	—	—	—	—	—	—	—	—	—	—	—

Note: Data includes pressure drop for filters and wet coil.



**Fan Performance**
**Table 32. Evaporator fan performance YS\*175F downflow or horizontal (SI)**

		External Static Pressure (Pascals)																				
		25.00		50.00		75.00		100.00		125.00		150.00		175.00		200.00		225.00		250.00		
m <sup>3</sup> /h	RPM	kW	RPM	kW	RPM	kW	RPM	kW	RPM	kW	RPM	kW	RPM	kW	RPM	kW	RPM	kW	RPM	kW	RPM	kW
<b>2.24 Nom kw Standard Motor &amp; Low Static Drive Accy</b>											<b>2.24 Nom kw Standard Motor &amp; High Static Drive Accy</b>											
7985	—	—	442	0.66	476	0.75	508	0.85	542	0.96	574	1.07	603	1.19	634	1.31	662	1.44	689	1.57		
8750	437	0.72	472	0.83	503	0.92	533	1.03	563	1.14	594	1.27	623	1.39	650	1.51	678	1.64	705	1.78		
9515	469	0.91	502	1.02	532	1.13	560	1.24	587	1.35	615	1.48	643	1.61	671	1.75	696	1.88	720	2.01		
10280	502	1.12	533	1.25	561	1.37	588	1.48	613	1.60	638	1.72	664	1.86	690	2.01	716	2.16	740	2.30		
11045	533	1.36	564	1.51	591	1.64	616	1.76	640	1.88	664	2.01	688	2.15	711	2.30	736	2.46	760	2.61		
<b>2.24 Nom kw Standard Motor Drive</b>											<b>3.73 Nom kw Oversized Motor &amp; Drive</b>											

Note: Data includes pressure drop for filters and wet coil.

**Table 33. Evaporator fan performance YS\*175F downflow or horizontal (IP)**

		External Static Pressure (Inches of Water)																				
		.10		.20		.30		.40		.50		.60		.70		.80		.90		1.00		
CFM	RPM	BHP	RPM	BHP	RPM	BHP	RPM	BHP	RPM	BHP	RPM	BHP	RPM	BHP	RPM	BHP	RPM	BHP	RPM	BHP	RPM	BHP
<b>3HP Standard Motor &amp; Low Static Drive Accessory</b>											<b>3HP Standard Motor &amp; High Static Drive Accessory</b>											
4700	—	—	442	0.88	476	1.00	508	1.14	542	1.29	574	1.44	603	1.59	634	1.76	662	1.93	689	2.10		
5150	437	0.97	472	1.11	503	1.24	533	1.38	563	1.53	594	1.70	623	1.86	650	2.02	678	2.20	705	2.39		
5600	469	1.22	502	1.37	532	1.51	560	1.66	587	1.81	615	1.98	643	2.16	671	2.35	696	2.52	720	2.70		
6050	502	1.50	533	1.68	561	1.83	588	1.99	613	2.14	638	2.31	664	2.50	690	2.70	716	2.89	740	3.08		
6500	533	1.82	564	2.02	591	2.20	616	2.36	640	2.53	664	2.70	688	2.88	711	3.08	736	3.29	760	3.50		
<b>3HP Standard Motor Drive</b>											<b>5HP Oversized Motor &amp; Drive</b>											

		External Static Pressure (Inches of Water)																				
		1.10		1.20		1.30		1.40		1.50		1.60		1.70		1.80		1.90		2.00		
CFM	RPM	BHP	RPM	BHP	RPM	BHP	RPM	BHP	RPM	BHP	RPM	BHP	RPM	BHP	RPM	BHP	RPM	BHP	RPM	BHP	RPM	BHP
<b>3HP Standard Motor &amp; High Static Drive Accessory</b>											<b>5HP Oversized Motor &amp; High Static Drive Accessory</b>											
4700	715	2.29	741	2.48	765	2.68	789	2.87	812	3.06	835	3.25	856	3.45	877	3.64	898	3.84	918	4.03		
5150	731	2.58	755	2.77	779	2.97	802	3.18	825	3.39	847	3.60	869	3.82	890	4.03	910	4.24	930	4.45		
5600	746	2.90	771	3.11	794	3.31	817	3.52	839	3.73	860	3.96	882	4.19	902	4.42	923	4.65	943	4.88		
6050	763	3.27	786	3.48	810	3.69	833	3.91	854	4.14	875	4.36	896	4.59	916	4.83	936	5.07	956	5.32		
6500	783	3.71	805	3.92	826	4.12	848	4.35	870	4.58	892	4.82	912	5.05	931	5.29	951	5.54	—	—		

Note: Data includes pressure drop for filters and wet coil.



**Performance Data**

*Fan Performance*

**Table 34. Evaporator fan performance YS\*200F downflow or horizontal (SI)**

External Static Pressure (Pascals)																					
		25.00		50.00		75.00		100.00		125.00		150.00		175.00		200.00		225.00		250.00	
m <sup>3</sup> /h	RPM	kW	RPM	kW	RPM	kW	RPM	kW	RPM	kW	RPM	kW	RPM	kW	RPM	kW	RPM	kW	RPM	kW	
2.24 Nom kw Standard Motor & Low Static Drive Accy									2.24 Nom kw Standard Motor & High Static Drive Accy												
9005	448	0.78	482	0.89	513	0.99	542	1.09	571	1.21	601	1.33	630	1.46	657	1.59	683	1.71	710	1.86	
9940	487	1.02	519	1.15	548	1.26	575	1.37	601	1.48	627	1.61	655	1.75	682	1.89	707	2.03	731	2.17	
10875	527	1.31	557	1.45	584	1.58	610	1.69	634	1.82	658	1.95	682	2.08	707	2.23	732	2.39	756	2.54	
11810	566	1.64	595	1.80	622	1.95	646	2.08	668	2.21	691	2.34	713	2.48	735	2.63	757	2.78	780	2.95	
12745	607	2.05	634	2.21	659	2.37	682	2.52	704	2.66	725	2.80	746	2.94	767	3.09	787	3.25	807	3.41	
2.24 Nom kw Standard Motor Drive									3.73 Nom kw Oversized Motor & Drive												

Continued

External Static Pressure (Pascals)																					
		275.00		300.00		325.00		350.00		375.00		400.00		425.00		450.00		475.00		500.00	
m <sup>3</sup> /h	RPM	kW	RPM	kW	RPM	kW	RPM	kW	RPM	kW	RPM	kW	RPM	kW	RPM	kW	RPM	kW	RPM	kW	
2.24 Nom kw Standard Motor & High Static Drive Accessory																					
9005	736	2.00	760	2.15	784	2.29	807	2.45	829	2.61	851	2.77	873	2.94	894	3.10	914	3.26	934	3.42	
9940	755	2.31	780	2.47	803	2.62	826	2.78	847	2.95	868	3.11	889	3.28	910	3.46	930	3.64	950	3.82	
10875	779	2.69	800	2.84	822	3.00	845	3.17	867	3.34	888	3.51	908	3.69	928	3.87	947	4.05	966	4.23	
11810	803	3.12	825	3.29	847	3.46	866	3.62	886	3.78	907	3.96	928	4.15	—	—	—	—	—	—	
12745	828	3.59	850	3.78	871	3.96	891	4.14	—	—	—	—	—	—	—	—	—	—	—	—	
3.73 Nom kw Oversized Motor & Drive										3.73 Nom kw Oversized Motor & High Static Drive Accessory											

Note: Data includes pressure drop for filters and wet coil.

**Table 35. Evaporator fan performance YS\*200F downflow or horizontal (IP)**

External Static Pressure (Inches of Water)																					
		.10		.20		.30		.40		.50		.60		.70		.80		.90		1.00	
CFM	RPM	BHP	RPM	BHP	RPM	BHP	RPM	BHP	RPM	BHP	RPM	BHP	RPM	BHP	RPM	BHP	RPM	BHP	RPM	BHP	
3HP Standard Motor & Low Static Drive Accessory									3HP Standard Motor & High Static Drive Accessory												
5300	448	1.05	482	1.19	513	1.33	542	1.46	571	1.62	601	1.79	630	1.96	657	2.13	683	2.30	710	2.49	
5850	487	1.37	519	1.54	548	1.68	575	1.83	601	1.99	627	2.16	655	2.35	682	2.54	707	2.72	731	2.91	
6400	527	1.76	557	1.95	584	2.11	610	2.27	634	2.44	658	2.61	682	2.79	707	2.99	732	3.20	756	3.41	
6950	566	2.20	595	2.41	622	2.62	646	2.79	668	2.96	691	3.14	713	3.33	735	3.52	757	3.73	780	3.96	
7500	607	2.75	634	2.97	659	3.18	682	3.38	704	3.57	725	3.76	746	3.94	767	4.15	787	4.36	807	4.57	
3HP Standard Motor Drive									5HP Oversized Motor & Drive												

Continued

External Static Pressure (Inches of Water)																					
		1.10		1.20		1.30		1.40		1.50		1.60		1.70		1.80		1.90		2.00	
CFM	RPM	BHP	RPM	BHP	RPM	BHP	RPM	BHP	RPM	BHP	RPM	BHP	RPM	BHP	RPM	BHP	RPM	BHP	RPM	BHP	
3HP Standard Motor & High Static Drive Accessory																					
5300	736	2.68	760	2.88	784	3.08	807	3.29	829	3.50	851	3.72	873	3.94	894	4.16	914	4.37	934	4.59	
5850	755	3.10	780	3.31	803	3.52	826	3.73	847	3.95	868	4.17	889	4.40	910	4.64	930	4.88	950	5.12	
6400	779	3.61	800	3.81	822	4.02	845	4.25	867	4.48	888	4.71	908	4.95	928	5.19	947	5.43	966	5.68	
6950	803	4.19	825	4.41	847	4.63	866	4.85	886	5.07	907	5.31	928	5.56	—	—	—	—	—	—	
7500	828	4.82	850	5.06	871	5.31	891	5.55	—	—	—	—	—	—	—	—	—	—	—	—	
5HP Oversized Motor & Drive										5HP Oversized Motor & High Static Drive Accessory											

Note: Data includes pressure drop for filters and wet coil.

Fan Performance

**Table 36. Evaporator fan performance YS\*250F downflow or horizontal (SI)**

External Static Pressure (Pascals)																								
		25.00		50.00		75.00		100.00		125.00		150.00		175.00		200.00		225.00		250.00				
m <sup>3</sup> /h	RPM	kW	RPM	kW	RPM	kW	RPM	kW	RPM	kW	RPM	kW	RPM	kW	RPM	kW	RPM	kW	RPM	kW	RPM	kW		
3.73 Nom kW Standard Motor & Low Static Drive Accessory									3.73 Nom kW Standard Motor and Drive															
11380	548	1.48	578	1.64	604	1.77	629	1.90	653	2.02	676	2.15	699	2.29	721	2.44	745	2.60	769	2.76				
12485	596	1.93	623	2.09	649	2.25	672	2.39	694	2.53	716	2.67	737	2.81	758	2.96	778	3.12	800	3.28				
13590	641	2.44	670	2.64	693	2.80	716	2.97	737	3.12	757	3.27	777	3.42	797	3.58	816	3.74	835	3.90				
14695	690	3.07	717	3.27	739	3.45	760	3.64	780	3.81	799	3.97	818	4.13	—	—	—	—	—	—				
15800	737	3.76	762	3.98	784	4.20	—	—	—	—	—	—	—	—	—	—	—	—	—	—				

3.73 Nom kW Standard Motor & High Static Drive Accessory (1)

Continued

External Static Pressure (Pascals)																								
		275.00		300.00		325.00		350.00		375.00		400.00		425.00		450.00		475.00		500.00				
m <sup>3</sup> /h	RPM	kW	RPM	kW	RPM	kW	RPM	kW	RPM	kW	RPM	kW	RPM	kW	RPM	kW	RPM	kW	RPM	kW	RPM	kW		
3.73 Nom kW Standard Motor & High Static Drive Accessory (1)																								
11380	792	2.92	814	3.08	835	3.24	855	3.40	877	3.57	898	3.75	919	3.93	939	4.12	—	—	—	—				
12485	821	3.46	843	3.64	864	3.82	885	3.99	904	4.17	—	—	—	—	—	—	—	—	—	—				
13590	853	4.07	873	4.26	—	—	—	—	—	—	—	—	—	—	—	—	—	—	—	—				
14695	—	—	—	—	—	—	—	—	—	—	—	—	—	—	—	—	—	—	—	—				
15800	—	—	—	—	—	—	—	—	—	—	—	—	—	—	—	—	—	—	—	—				

3.73 Nom kW Standard Motor & High Static Drive Accessory (2)

Note: Data includes pressure drop for filters and wet coil.

**Table 37. Evaporator fan performance YS\*250F downflow or horizontal (IP)**

External Static Pressure (Inches of Water)																								
		.10		.20		.30		.40		.50		.60		.70		.80		.90		1.00				
CFM	RPM	BHP	RPM	BHP	RPM	BHP	RPM	BHP	RPM	BHP	RPM	BHP	RPM	BHP	RPM	BHP	RPM	BHP	RPM	BHP	RPM	BHP		
5HP Standard Motor & Low Static Drive Accessory											5HP Standard Motor and Drive													
6700	548	1.98	578	2.19	604	2.37	629	2.54	653	2.71	676	2.89	699	3.07	721	3.27	745	3.48	769	3.70				
7350	596	2.59	623	2.81	649	3.02	672	3.21	694	3.39	716	3.58	737	3.77	758	3.97	778	4.18	800	4.40				
8000	641	3.27	670	3.54	693	3.76	716	3.99	737	4.19	757	4.39	777	4.59	797	4.80	816	5.02	835	5.24				
8650	690	4.12	717	4.39	739	4.63	760	4.89	780	5.11	799	5.32	818	5.54	—	—	—	—	—	—				
9300	737	5.04	762	5.34	784	5.63	—	—	—	—	—	—	—	—	—	—	—	—	—	—				

5HP Standard Motor & High Static Drive Accessory (1)

Continued

External Static Pressure (Inches of Water)																								
		1.10		1.20		1.30		1.40		1.50		1.60		1.70		1.80		1.90		2.00				
CFM	RPM	BHP	RPM	BHP	RPM	BHP	RPM	BHP	RPM	BHP	RPM	BHP	RPM	BHP	RPM	BHP	RPM	BHP	RPM	BHP	RPM	BHP		
5HP Standard Motor & High Static Drive Accessory (1)																								
6700	792	3.92	814	4.13	835	4.34	855	4.55	877	4.79	898	5.03	919	5.28	939	5.52	—	—	—	—				
7350	821	4.64	843	4.88	864	5.12	885	5.36	904	5.59	—	—	—	—	—	—	—	—	—	—				
8000	853	5.46	873	5.72	—	—	—	—	—	—	—	—	—	—	—	—	—	—	—	—				
8650	—	—	—	—	—	—	—	—	—	—	—	—	—	—	—	—	—	—	—	—				
9300	—	—	—	—	—	—	—	—	—	—	—	—	—	—	—	—	—	—	—	—				

5HP Standard Motor & High Static Drive Accessory (2)

Note: Data includes pressure drop for filters and wet coil.



**Performance Data**

*Fan Performance*

**Table 38. Evaporator fan performance WS\*155E downflow or horizontal (SI)**

External Static Pressure (Pascals)																				
25.00		50.00		75.00		100.00		125.00		150.00		175.00		200.00		225.00		250.00		
m <sup>3</sup> /h	RPM	kW	RPM	kW	RPM	kW	RPM	kW	RPM	kW	RPM	kW	RPM	kW	RPM	kW	RPM	kW	RPM	kW
1.49 Nom kW Standard Motor & Low Static Drive Accessory										1.49 Nom kW Standard Motor & High Static Drive Accessory										
6800	346	0.35	388	0.43	426	0.51	465	0.60	502	0.70	537	0.80	570	0.91	601	1.02	631	1.14	660	1.27
7650	377	0.47	417	0.56	452	0.65	486	0.74	521	0.85	554	0.96	585	1.07	617	1.19	646	1.31	673	1.44
8500	409	0.62	448	0.73	480	0.82	512	0.92	542	1.03	574	1.15	604	1.27	632	1.38	661	1.51	689	1.65
9350	442	0.80	479	0.92	510	1.03	539	1.13	567	1.24	595	1.36	624	1.49	652	1.63	678	1.76	703	1.89
10200	475	1.01	510	1.14	541	1.27	568	1.38	594	1.50	620	1.62	645	1.74	672	1.89	698	2.04	723	2.18
1.49 Nom kW Standard Motor Drive										2.24 Nom kW Oversized Motor & Drive										

**Continued**

External Static Pressure (Pascals)																				
275.00		300.00		325.00		350.00		375.00		400.00		425.00		450.00		475.00		500.00		
m <sup>3</sup> /h	RPM	kW	RPM	kW	RPM	kW	RPM	kW	RPM	kW	RPM	kW	RPM	kW	RPM	kW	RPM	kW	RPM	kW
1.49 Nom kW Standard Motor & High Static Drive Accessory																				
6800	687	1.39	714	1.51	739	1.64	763	1.76	787	1.88	809	2.01	831	2.14	851	2.27	—	—	—	—
7650	700	1.57	726	1.71	751	1.85	775	1.99	799	2.13	821	2.27	843	2.40	—	—	—	—	—	—
8500	714	1.78	739	1.93	764	2.07	788	2.22	811	2.38	833	2.54	—	—	—	—	—	—	—	—
9350	730	2.03	755	2.18	779	2.33	802	2.48	—	—	—	—	—	—	—	—	—	—	—	—
10200	747	2.32	770	2.46	—	—	—	—	—	—	—	—	—	—	—	—	—	—	—	—
2.24 Nom kW Oversized Motor & Drive																				

**Notes:**

1. Data includes pressure drop for filters and wet coil.
2. For 200 volt, use 50 Hz reference Performance Data Table and Standard Motor & Sheave/Fan Speed (RPM) to determine applicable operating range.

**Table 39. Evaporator fan performance WS\*155E downflow or horizontal (IP)**

External Static Pressure (Inches of Water)																				
.10		.20		.30		.40		.50		.60		.70		.80		.90		1.00		
CFM	RPM	BHP	RPM	BHP	RPM	BHP	RPM	BHP	RPM	BHP	RPM	BHP	RPM	BHP	RPM	BHP	RPM	BHP	RPM	BHP
2HP Standard Motor & Low Static Drive Accessory										2HP Standard Motor & High Static Drive Accessory										
4000	346	0.47	388	0.57	426	0.68	465	0.81	502	0.94	537	1.07	570	1.22	601	1.37	631	1.53	660	1.70
4500	377	0.63	417	0.75	452	0.87	486	1.00	521	1.14	554	1.29	585	1.43	617	1.60	646	1.76	673	1.93
5000	409	0.83	448	0.98	480	1.10	512	1.23	542	1.38	574	1.54	604	1.70	632	1.86	661	2.03	689	2.21
5500	442	1.07	479	1.23	510	1.38	539	1.51	567	1.66	595	1.82	624	2.00	652	2.18	678	2.36	703	2.53
6000	475	1.36	510	1.53	541	1.70	568	1.85	594	2.01	620	2.17	645	2.34	672	2.53	698	2.73	723	2.92
2HP Standard Motor Drive										3HP Oversized Motor & Drive										

**Continued**

External Static Pressure (Inches of Water)																				
1.10		1.20		1.30		1.40		1.50		1.60		1.70		1.80		1.90		2.00		
CFM	RPM	BHP	RPM	BHP	RPM	BHP	RPM	BHP	RPM	BHP	RPM	BHP	RPM	BHP	RPM	BHP	RPM	BHP	RPM	BHP
2HP Standard Motor & High Static Drive Accessory										3HP Oversized Motor & Drive										
4000	687	1.86	714	2.03	739	2.19	763	2.36	787	2.53	809	2.70	831	2.87	851	3.05	—	—	—	—
4500	700	2.11	726	2.30	751	2.48	775	2.67	799	2.85	821	3.04	843	3.22	—	—	—	—	—	—
5000	714	2.39	739	2.58	764	2.78	788	2.98	811	3.19	833	3.40	—	—	—	—	—	—	—	—
5500	730	2.72	755	2.92	779	3.12	802	3.33	—	—	—	—	—	—	—	—	—	—	—	—
6000	747	3.11	770	3.30	—	—	—	—	—	—	—	—	—	—	—	—	—	—	—	—

**Notes:**

1. Data includes pressure drop for filters and wet coil.
2. For 200 volt, use 50 Hz reference Performance Data Table and Standard Motor & Sheave/Fan Speed (RPM) to determine applicable operating range.

**Fan Performance**
**Table 40. Evaporator fan performance WS\*200E downflow or horizontal (SI)**

		External Static Pressure (Pascals)																				
		25.00		50.00		75.00		100.00		125.00		150.00		175.00		200.00		225.00		250.00		
m <sup>3</sup> /h	RPM	kW	RPM	kW	RPM	kW	RPM	kW	RPM	kW	RPM	kW	RPM	kW	RPM	kW	RPM	kW	RPM	kW	RPM	kW
2.24 Nom kw Standard Motor Drive										2.24 Nom kw Standard Motor Drive & High Static Drive Accessory												
8970	—	—	—	—	446	0.80	475	0.91	504	1.03	533	1.15	561	1.28	588	1.42	613	1.56	636	1.69		
10090	—	—	449	0.94	481	1.05	510	1.18	536	1.31	561	1.44	587	1.58	611	1.72	636	1.87	660	2.03		
11210	451	1.10	486	1.25	517	1.38	545	1.51	570	1.65	593	1.80	616	1.95	639	2.10	661	2.25	684	2.41		
12330	491	1.45	525	1.62	554	1.77	581	1.91	605	2.06	628	2.21	649	2.38	670	2.54	691	2.71	711	2.87		
13450	531	1.86	563	2.06	592	2.24	617	2.39	641	2.54	663	2.70	684	2.88	704	3.06	723	3.24	742	3.42		
										3.73 Nom kw Oversized Motor & Low Static Drive Accessory												

Continued

		External Static Pressure (Pascals)																				
		275.00		300.00		325.00		350.00		375.00		400.00		425.00		450.00		475.00		500.00		
m <sup>3</sup> /h	RPM	kW	RPM	kW	RPM	kW	RPM	kW	RPM	kW	RPM	kW	RPM	kW	RPM	kW	RPM	kW	RPM	kW	RPM	kW
2.24 Nom kw Standard Motor & High Static Drive Accessory										3.73 Nom kw Oversized Motor & Drive												
8970	657	1.83	678	1.97	699	2.11	721	2.26	742	2.41	762	2.57	782	2.72	801	2.87	820	3.03	837	3.18		
10090	683	2.18	704	2.34	724	2.49	743	2.65	762	2.81	780	2.97	799	3.13	817	3.30	836	3.47	854	3.65		
11210	706	2.57	728	2.75	749	2.92	769	3.10	787	3.27	805	3.44	822	3.62	839	3.79	856	3.97	872	4.15		
12330	731	3.04	751	3.22	772	3.40	792	3.59	811	3.78	830	3.97	848	4.17	—	—	—	—	—	—		
13450	760	3.60	779	3.78	798	3.96	816	4.15	—	—	—	—	—	—	—	—	—	—	—	—		
										3.73 Nom kw Oversized Motor & Low Static Drive Accessory												

**Notes:**

1. Data includes pressure drop for filters and wet coil.
2. For 200 volt, use 50 Hz reference Performance Data Table and Standard Motor & Sheave/Fan Speed (RPM) to determine applicable operating range.

**Table 41. Evaporator fan performance WS\*200E downflow or horizontal (IP)**

		External Static Pressure (Inches of Water)																				
		.10		.20		.30		.40		.50		.60		.70		.80		.90		1.00		
CFM	RPM	BHP	RPM	BHP	RPM	BHP	RPM	BHP	RPM	BHP	RPM	BHP	RPM	BHP	RPM	BHP	RPM	BHP	RPM	BHP	RPM	BHP
3HP Standard Motor Drive										3HP Standard Motor Drive & High Static Drive Accessory												
5200	—	—	—	—	446	1.07	475	1.22	504	1.38	533	1.54	561	1.72	588	1.90	613	2.09	636	2.27		
5900	—	—	449	1.26	481	1.41	510	1.58	536	1.76	561	1.94	587	2.12	611	2.31	636	2.51	660	2.72		
6600	451	1.47	486	1.67	517	1.85	545	2.02	570	2.21	593	2.41	616	2.61	639	2.81	661	3.02	684	3.23		
7300	491	1.95	525	2.17	554	2.38	581	2.56	605	2.76	628	2.97	649	3.19	670	3.41	691	3.63	711	3.85		
8000	531	2.50	563	2.77	592	3.00	617	3.21	641	3.41	663	3.62	684	3.86	704	4.10	723	4.34	742	4.58		
										5HP Oversized Motor & Low Static Drive Accessory												

Continued

		External Static Pressure (Inches of Water)																				
		1.10		1.20		1.30		1.40		1.50		1.60		1.70		1.80		1.90		2.00		
CFM	RPM	BHP	RPM	BHP	RPM	BHP	RPM	BHP	RPM	BHP	RPM	BHP	RPM	BHP	RPM	BHP	RPM	BHP	RPM	BHP	RPM	BHP
3HP Standard Motor & High Static Drive Accessory										5HP Oversized Motor & Drive												
5200	657	2.45	678	2.64	699	2.84	721	3.03	742	3.24	762	3.44	782	3.65	801	3.85	820	4.06	837	4.26		
5900	683	2.93	704	3.14	724	3.34	743	3.55	762	3.76	780	3.98	799	4.20	817	4.43	836	4.66	854	4.89		
6600	706	3.45	728	3.68	749	3.92	769	4.15	787	4.38	805	4.62	822	4.85	839	5.09	856	5.32	872	5.57		
7300	731	4.08	751	4.31	772	4.56	792	4.81	811	5.07	830	5.33	848	5.59	—	—	—	—	—	—		
8000	760	4.82	779	5.07	798	5.32	816	5.57	—	—	—	—	—	—	—	—	—	—	—	—		
										5HP Oversized Motor & Low Static Drive Accessory												

**Notes:**

1. Data includes pressure drop for filters and wet coil.
2. For 200 volt, use 50 Hz reference Performance Data Table and Standard Motor & Sheave/Fan Speed (RPM) to determine applicable operating range.



## Performance Data

### Fan Speeds

**Table 42. T/YS\*155–250 standard motor and drive/fan speed (rpm)**

Unit Model No.	6 Turns Open	5 Turns Open	4 Turns Open	3 Turns Open	2 Turns Open	1Turns Open	Closed
T/YS*155F	466	501	535	570	604	639	N/A
T/YS*175F	500	537	574	611	648	685	N/A
T/YS*200F	500	537	574	611	648	685	N/A
T/YS*250F	587	619	651	682	714	746	N/A

**Notes:**

1. \* indicates both horizontal and downflow units
2. Factory set at 3 turns open.

**Table 43. T/YS\*155–250 standard motor and low static fan drive**

Unit Model No.	6 Turns Open	5 Turns Open	4 Turns Open	3 Turns Open	2 Turns Open	1Turns Open	Closed
T/YS*155F	376	404	432	460	488	516	N/A
T/YS*175F	418	442	466	489	513	537	N/A
T/YS*200F	418	442	466	489	513	537	N/A
T/YS*250F	492	524	556	587	619	651	N/A

**Note:** \* indicates both horizontal and downflow units

**Table 44. T/YS\*155–250 standard motor and high static drive accessory/fan speed (rpm)**

Unit Model No.	6 Turns Open	5 Turns Open	4 Turns Open	3 Turns Open	2 Turns Open	1Turns Open	Closed
T/YS*155F	600	628	656	683	711	739	N/A
T/YS*175F	685	722	759	796	833	870	N/A
T/YS*200F	685	722	759	796	833	870	N/A
T/YS*250F	702	740	778	815	853	891	N/A

**Note:** \* indicates both horizontal and downflow units

**Table 45. T/YS\*155–250 oversized motor and drive/fan speed (rpm)**

Unit Model No.	6 Turns Open	5 Turns Open	4 Turns Open	3 Turns Open	2 Turns Open	1Turns Open	Closed
T/YS*155F	621	667	713	758	804	850	N/A
T/YS*175F	682	714	746	777	809	841	N/A
T/YS*200F	682	714	746	777	809	841	N/A
T/YS*250F	702	740	778	815	853	891	N/A

**Note:** \* indicates both horizontal and downflow units

**Fan Speeds**
**Table 46. WS\*155, 200 standard motor and drive/fan speed (rpm)**

Unit Model No.	6 Turns Open	5 Turns Open	4 Turns Open	3 Turns Open	2 Turns Open	1Turns Open	Closed
WS*155ED, ET	416	447	478	509	540	571	N/A
WS*200ED, ET	574	611	648	685	722	759	N/A

**Note:** \* indicates both horizontal and downflow units

**Table 47. WS\*155, 200 standard motor and low static fan drive**

Unit Model No.	6 Turns Open	5 Turns Open	4 Turns Open	3 Turns Open	2 Turns Open	1Turns Open	Closed
WS*155ED	316	339	363	386	410	433	N/A
WS*200ED	418	449	480	512	543	574	N/A

**Note:** \* indicates both horizontal and downflow units

**Table 48. WS\*155, 200 standard motor and high static drive accessory/fan speed (rpm)**

Unit Model No.	6 Turns Open	5 Turns Open	4 Turns Open	3 Turns Open	2 Turns Open	1Turns Open	Closed
WS*155ED	571	602	633	663	694	725	N/A
WS*200ED	574	611	648	685	722	759	N/A

**Note:** \* indicates both horizontal and downflow units

**Table 49. WS\*155, 200 oversized motor and drive/fan speed (rpm)**

Unit Model No.	6 Turns Open	5 Turns Open	4 Turns Open	3 Turns Open	2 Turns Open	1Turns Open	Closed
WS*155ED	621	667	698	728	759	850	N/A
WS*200ED	702	740	777	814	851	891	N/A

**Note:** \* indicates both horizontal and downflow units



## Performance Data

### Static Pressure Drop

**Table 50. T/YS\*155-250—static pressure drops through accessories—pascals**

Unit Model No.	Airflow m <sup>3</sup> /h	Standard Filters	Economizer with OA/RA Dampers <sup>(a)</sup>		Electric Heater - Nom kW <sup>(b)</sup>			
			100% OA	100% RA	5-12	14-27	33-41	45-54
D155	7140	6	8	5	7	9	10	—
D155	8500	9	11	7	9	12	15	—
D155	9860	12	15	10	12	16	20	—
H155	7140	6	8	5	7	9	10	—
H155	8500	9	11	7	9	12	15	—
H155	9860	12	15	10	12	16	20	—
D175	7985	7	10	7	8	10	13	—
D175	9515	11	14	9	12	15	18	—
D175	11045	14	18	12	16	20	24	—
H175	7985	7	10	7	8	10	13	—
H175	9515	11	14	9	12	15	18	—
H175	11045	14	18	12	16	20	24	—
D200	9005	12	29	6	—	11	14	16
D200	10875	18	42	9	—	16	21	23
D200	12745	24	57	13	—	22	29	31
H200	9005	10	33	6	—	11	14	16
H200	10875	15	48	9	—	16	21	23
H200	12745	21	66	13	—	22	29	31
D250	11380	20	46	9	—	17	22	25
D250	13590	28	66	13	—	24	31	36
D250	15800	38	89	18	—	33	42	49
H250	11380	16	52	9	—	17	22	25
H250	13590	23	75	13	—	24	31	36
H250	15800	31	101	18	—	33	42	49

(a) OA = Outside Air, RA = Return Air

(b) Nominal kW ratings are at 415 V. Not all Heater sizes may be available.

\* Indicates both horizontal and downflow units.



**Static Pressure Drop**
**Table 51. T/YS\*155-250—static pressure drops through accessories—(inches water column)**

Unit Model No.	Airflow CFM	Standard Filters	Economizer with OA/RA Dampers <sup>(a)</sup>		Electric Heater - Nom kW <sup>(b)</sup>			
			100% OA	100% RA	5-12	14-27	33-41	45-54
D155	4200	0.02	0.03	0.02	0.03	0.03	0.04	—
D155	5000	0.04	0.05	0.03	0.04	0.05	0.06	—
D155	5800	0.05	0.06	0.04	0.05	0.07	0.08	—
H155	4200	0.02	0.03	0.02	0.03	0.03	0.04	—
H155	5000	0.04	0.05	0.03	0.04	0.05	0.06	—
H155	5800	0.05	0.06	0.04	0.05	0.07	0.08	—
D175	4700	0.03	0.04	0.03	0.03	0.04	0.05	—
D175	5600	0.04	0.06	0.04	0.05	0.06	0.07	—
D175	6500	0.06	0.07	0.05	0.06	0.08	0.10	—
H175	4700	0.03	0.04	0.03	0.03	0.04	0.05	—
H175	5600	0.04	0.06	0.04	0.05	0.06	0.07	—
H175	6500	0.06	0.07	0.05	0.06	0.08	0.10	—
D200	5300	0.05	0.11	0.03	—	0.04	0.06	0.06
D200	6400	0.07	0.17	0.04	—	0.06	0.08	0.09
D200	7500	0.10	0.23	0.05	—	0.09	0.11	0.13
H200	5300	0.04	0.13	0.03	—	0.04	0.06	0.06
H200	6400	0.06	0.19	0.04	—	0.06	0.08	0.09
H200	7500	0.08	0.26	0.05	—	0.09	0.11	0.13
D250	6700	0.08	0.19	0.04	—	0.07	0.09	0.10
D250	8000	0.11	0.27	0.05	—	0.10	0.12	0.15
D250	9300	0.15	0.36	0.07	—	0.13	0.17	0.20
H250	6700	0.06	0.21	0.04	—	0.07	0.09	0.10
H250	8000	0.09	0.30	0.05	—	0.10	0.12	0.15
H250	9300	0.13	0.40	0.07	—	0.13	0.17	0.20

(a) OA = Outside Air, RA = Return Air  
 (b) Nominal kW ratings are at 415 V. Not all Heater sizes may be available.  
 \* Indicates both horizontal and downflow units.



## Performance Data

### Static Pressure Drop

**Table 52. WS\*155, 200—static pressure drops through accessories—pascals**

Unit Model No.	Airflow m <sup>3</sup> /h	Standard Filters	Economizer with OA/RA Dampers <sup>(a)</sup>		Electric Heater - Nom kW <sup>(b)</sup>			
			100% OA	100% RA	5-14	16-27	33-41	45-54
D155	6800	6	45	5	7	7	10	—
D155	8500	8	62	5	10	12	15	—
D155	10200	11	87	7	17	20	22	—
H155	6800	6	45	5	7	7	10	—
H155	8500	8	62	5	10	12	15	—
H155	10200	11	87	7	17	20	22	—
D200	8970	8	37	5	—	10	12	15
D200	11210	14	57	7	—	17	20	22
D200	13450	19	77	12	—	25	27	35
H200	8970	8	50	7	—	12	15	17
H200	11210	15	75	10	—	22	27	32
H200	13450	24	124	17	—	37	42	52

(a) OA = Outside Air, RA = Return Air

(b) Nominal kW ratings are at a 415 V

\* Indicates both horizontal and downflow units.

**Table 53. WS\*155, 200—static pressure drops through accessories—(inches water column)**

Unit Model No.	Airflow CFM	Standard Filters	Economizer with OA/RA Dampers <sup>(a)</sup>		Electric Heater - Nom kW <sup>(b)</sup>			
			100% OA	100% RA	5-14	16-27	33-41	45-54
D155	4000	0.02	0.18	0.02	0.03	0.03	0.04	—
D155	5000	0.03	0.25	0.02	0.04	0.05	0.06	—
D155	6000	0.05	0.35	0.03	0.07	0.08	0.09	—
H155	4000	0.02	0.18	0.02	0.03	0.03	0.04	—
H155	5000	0.03	0.25	0.02	0.04	0.05	0.06	—
H155	6000	0.05	0.35	0.03	0.07	0.08	0.09	—
D200	5200	0.03	0.15	0.02	—	0.04	0.05	0.06
D200	6600	0.05	0.23	0.03	—	0.07	0.08	0.09
D200	8000	0.07	0.31	0.05	—	0.10	0.11	0.14
H200	5200	0.03	0.20	0.03	—	0.05	0.06	0.07
H200	6600	0.06	0.30	0.04	—	0.09	0.11	0.13
H200	8000	0.10	0.50	0.07	—	0.15	0.17	0.21

(a) OA = Outside Air, RA = Return Air

(b) Nominal kW ratings are at a 415 V

\* Indicates both horizontal and downflow units.

# Controls

## ReliaTel Controlled Units

Zone Sensors are the building occupant's comfort control devices. They replace the conventional electro-mechanical thermostats. The following zone sensor options are available for Voyager units:

### Differential Enthalpy

Differential Enthalpy Replaces the standard dry bulb control with two enthalpy sensors that compare total heat content of the indoor air and outdoor air to determine the most efficient air source. This control option offers the highest level of comfort control, plus energy efficiency, available.

### Differential Pressure Switches

This factory or field-installed option allows individual fan failure and dirty filter indication. The fan failure switch will disable all unit functions and "flash" the Service LED on the zone sensor. The dirty filter switch will light the Service LED on the zone sensor and will allow continued unit operation.

### Manual Changeover

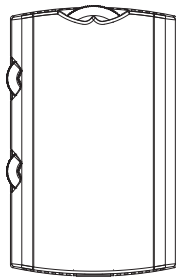

Heat, Cool or Off System Switch. Fan Auto or Off Switch. One temperature setpoint lever.

### Manual/Automatic Changeover

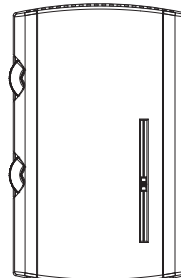

Auto, Heat, Cool or Off System Switch. Fan Auto or Off Switch. Two temperature setpoint levers.

### Manual/Automatic Changeover

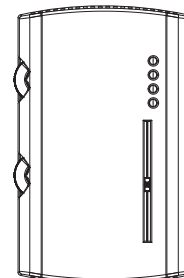

Auto, Heat, Cool or Off System Switch. Fan Auto or Off Switch. Two temperature setpoint levers. Status Indication LED lights, System On, Heat, Cool, or Service.

### RA Remote Sensor & Room Remote Sensor

The RA Remote Sensor is a Return Air Remote Sensor which can be mounted in the return air duct to report return air temperature. The Room Remote Sensor is a Space Remote Sensor which can be mounted on the wall to report/control from a remote location in the space.

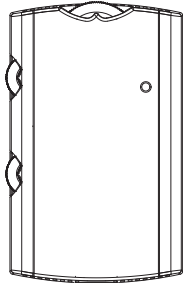
**Manual/Automatic  
Changeover**

Auto, Heat, Cool or Off System Switch. Fan Auto or Off Switch. Two temperature setpoint levers.

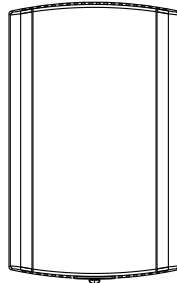
**Remote Sensor**

Sensor(s) available for all zone sensors to provide remote sensing capabilities.

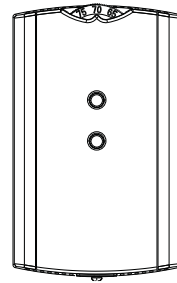
**Integrated Comfort™  
System**

Sensor(s) available with optional temperature adjustment and override buttons to provide central control through a Trane Integrated Comfort™ system.

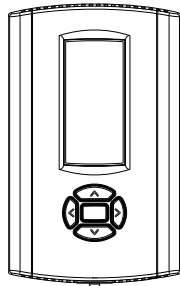
**Programmable Night  
Setback**

Auto or manual changeover with seven-day programming. Keyboard selection of Heat, Cool, Fan, Auto, or On. All programmable sensors have System On, Heat, Cool, Service LED/indicators as standard. Night Setback Sensors have one (1) Occupied, one (1) Unoccupied, and one (1) Override program per day.

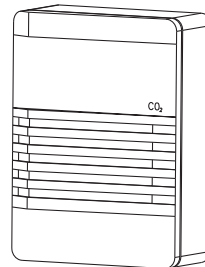
**CO<sub>2</sub> Sensing**

The CO<sub>2</sub> sensor shall have the ability to monitor space occupancy levels within the building by measuring the parts per million of CO<sub>2</sub> (Carbon Dioxide) in the air. As the CO<sub>2</sub> levels increase, the outside air damper modulates to meet the CO<sub>2</sub> space ventilation requirements. The CO<sub>2</sub> accessory shall be available as field installed.

**Digital Display Programmable Thermostat with Built-In Relative Humidity Sensing (3H/2C)**

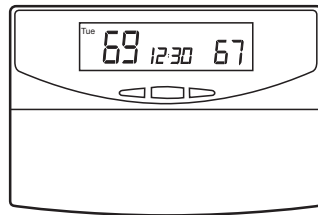

Three Heat/Two Cool digital display thermostat with built-in humidity control and display. This thermostat combines both humidity and dry bulb into one. Fully programmable with night setback.

**Digital Display Programmable Thermostat (3H/2C)**

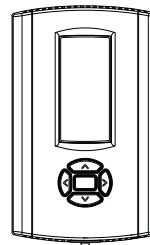

Two Heat/Two Cool auto changeover digital display thermostat. Seven-day programmable stat with night setback shall be available.

**Touchscreen Programmable Thermostat (2H/2C)**

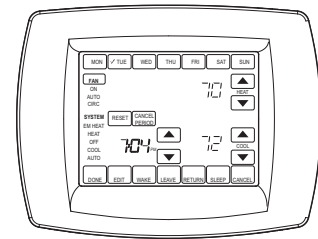

Two Heat/Two Cool programmable thermostat with touch screen digital display. Menu-driven programming. Effortless set-up. Program each day separately with no need to copy multiple days. All programming can be done on one screen. Easy to read and use. Large, clear backlit digital display.

**Digital Display Thermostat (3H/2C)**

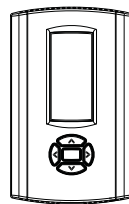

Three Heat, Two Cool auto changeover digital display thermostat.

**Remote Potentiometer**

Minimum position setting of economizer can be remotely adjusted with this accessory.

**Trane Communication Interface (TCI)**

This factory or field-installed micro-processor interface allows the unit to communicate to Trane's Integrated Comfort™ system.

**Economizer Controls**

The standard equipment offering is a fixed dry bulb changeover control. In addition, there are two optional controls, Enthalpy and Differential Enthalpy Control.

**Enthalpy Control**

Replaces the dry bulb control with a wet bulb changeover controller which has a fully adjustable setpoint. Enthalpy control offers a higher level of comfort control, along with energy savings potential, than the standard dry bulb control. This is due to the additional wet bulb sensing capability.



# Electrical Data

**Table 54. TS\* auxiliary electric heat capacity**

Unit Model No. (a)	Total heater kW (b) (c)	No. of Stages	Stage 1 heater kW (b)	Stage 2 heater kW (b)
TS*155FD	26.9	2	13.4	13.4
TS*175FD	26.9	2	13.4	13.4
	40.3	2	26.9	13.4
TS*200FD	26.9	2	13.4	13.4
TS*250FD	40.3	2	26.9	13.4
	53.8	2	26.9	26.9

**Note:** To calculate temperature rise across the electric heat use the following formulas:  
 Temp Rise Across Electric Heater - °C = 2982 \* Heater Capacity (kW)/Airflow (m<sup>3</sup>/h)  
 Temp Rise Across Electric Heater - °F = 3160 \* Heater Capacity (kW)/Airflow (cfm)

(a) \* = downflow and horizontal units.

(b) Heaters are rated at 415V. For other than rated voltage, apply the following formula - kW = (Required Voltage/415)<sup>2</sup> x Rated kW.

(c) Not all Heater Models are available.

**Table 55. TS\* electric heater voltage correction factors (apply to auxiliary electric heat capacity)**

Nominal Voltage	Distribution Voltage	Capacity Multiplier
415	380	0.84
	400	0.93
	415	1.00

**Table 56. TS\* unit wiring**

Unit Model No. (a)	Voltage	Standard Indoor Fan Motor—MCA	Oversized Indoor Fan Motor—MCA
TS*155FD	380–415	43	47
TS*175FD	380–415	46	50
TS*200FD	380–415	50	54
TS*250FD	380–415	36	—

(a) \* = downflow and horizontal units.

**Table 57. TS\* unit wiring with electric heat (single point connection)(a)**

Unit Model No. (b)	Heater kW Rating	Unit Supply Power	Control Stages	Standard Indoor Motor MCA	Oversized Motor MCA
TS*155ED	11.3–13.5	380–415/50/3	1	43	47
TS*155FD	22.6–26.9	380–415/50/3	2	54	58
TS*155FD	33.8–40.4	380–415/50/3	2	62	67
TS*175FD	22.6–26.9	380–415/50/3	2	54	58
TS*175FD	33.8–40.4	380–415/50/3	2	67	67
TS*200FD	22.6–26.9	380–415/50/3	2	54	58
TS*200FD	33.8–40.4	380–415/50/3	2	62	67
TS*200FD	45.1–53.8	380–415/50/3	2	80	84
TS*250FD	22.6–26.9	380–415/50/3	2	64	—
TS*250FD	33.8–40.4	380–415/50/3	2	67	—
TS*250FD	45.1–53.8	380–415/50/3	2	84	—

(a) All units to be installed under local codes.

(b) \* = downflow and horizontal units.

**Table 58. TS\* electric characteristics—evaporator fan motor—50 cycle**

Unit Model No. <sup>(a)</sup>	Standard Evaporator Motor							Oversized Evaporator Motor						
	No.	Volts	Ph	Watts	FLA	LRA	Service Factor	No.	Volts	Ph	Watts	FLA	LRA	Service Factor
TS*155FD	1	380–415	3	1500	4.6	36.4	1.15	1	380–415	3	2200	6.5	57	1.15
TS*175FD	1	380–415	3	2200	6.5	57.0	1.15	1	380–415	3	3700	7.4	71.9	1.15
TS*200FD	1	380–415	3	2200	6.5	57.0	1.15	1	380–415	3	3700	7.0	65.1	1.15
TS*250FD	1	380–415	3	3700	7.4	71.9	1.15	—	—	—	—	—	—	—

(a) \* = downflow and horizontal units.

**Table 59. TS\* electric characteristics—compressor motor and condenser motor—50 cycle**

Unit Model No. <sup>(a)</sup>	Compressor Motors							Condenser Fan Motors			
	No.	Volts	Ph	Watts	rpm	Amps <sup>(b)</sup>		No.	Ph	Amps <sup>b</sup>	
						RLA	LRA			FLA	LRA
TS*155FD	2	380–415	3	8200/4100	2900	17/10.7	142/64	2	3	1.4	4.65
TS*175FD	2	380–415	3	9200/3800	2900	21.4/7.9	142/48	2	3	2.2	7.4
TS*200FD	2	380–415	3	10900/6400	2900	22.1/14	147/101	2	3	2.2	7.4
TS*250FD	2	380–415	3	9200/9200	2900	21.4/21.4	142/142	2	3	2.2	7.4

(a) \* = downflow and horizontal units.

(b) For Compressor Motors and Condenser Fan Motors: Amp draw for each motor; multiply value by number of motors to determine total amps.

**Table 60. YS\* unit wiring**

Unit Model No. <sup>(a)</sup>	Voltage	Standard Indoor Fan Motor—MCA	Oversized Indoor Fan Motor—MCA
YS*155FD	380–415	43	47
YS*175FD	380–415	46	50
YS*200FD	380–415	54	58
YS*250FD	380–415	64	—

(a) \* = downflow and horizontal units.

**Table 61. YS\* electric characteristics—evaporator fan motor—50 cycle**

Unit Model No. <sup>(a)</sup>	Standard Evaporator Motor							Oversized Evaporator Motor						
	No.	Volts	Ph	Watts	FLA	LRA	Service Factor	No.	Volts	Ph	Watts	FLA	LRA	Service Factor
YS*155FD	1	380–415	3	1500	4.6	36.4	1.15	1	380/415	3	2200	6.5	57	1.15
YS*175FD	1	380–415	3	2200	6.5	57.0	1.15	1	380/415	3	3700	7.4	71.9	1.15
YS*200FD	1	380–415	3	2200	6.5	57.0	1.15	1	380/415	3	3700	7.0	65.1	1.15
YS*250FD	1	380–415	3	3700	7.4	71.9	1.15	—	—	—	—	—	—	—

(a) \* = downflow and horizontal units.

## Electrical Data

**Table 62. YS\* electric characteristics—compressor motor and condenser motor—50 cycle**

Unit Model No. (a)	Compressor Motors							Condenser Fan Motors			
	No.	Volts	Ph	Watts	rpm	Amps (b)		No.	Ph	Amps (b)	
						RLA	LRA			FLA	LRA
YS*155FD	2	380–415	3	8200/4100	2900	17/10.7	142/64	2	3	1.4	4.65
YS*175FD	2	380–415	3	9200/3800	2900	21.4/7.9	142/48	2	3	2.2	7.4
YS*200FD	2	380–415	3	10900/6400	2900	22.1/14	147/101	2	3	2.2	7.4
YS*250FD	2	380–415	3	9200/9200	2900	21.4/21.4	142/142	2	3	2.2	7.4

(a) \* = downflow and horizontal units.

(b) For Compressor Motors and Condenser Fan Motors: Amp draw for each motor; multiply value by number of motors to determine total amps.

**Table 63. WS\* auxiliary electric heat capacity**

Unit Model No. (a)	Total heater kW (b) (c)	No. of Stages	Stage 1 heater kW (b)	Stage 2 heater kW (b)
WS*155ED	40.3	2	26.9	13.4
WS*155ET	37.5	2	25.0	12.5
WS*200ED	26.9	2	13.4	13.4
	40.3	2	26.9	13.4
	53.8	2	26.9	26.9
WS*200ET	25.0	1	25.0	—
	37.5	2	25.0	12.5
	50.0	2	25.0	25.0

**Note:** To calculate temperature rise across the electric heat use the following formulas:

Temp Rise Across Electric Heater - °C =  $2982 \times \text{Heater Capacity (kW)} / \text{Airflow (m}^3/\text{h)}$

Temp Rise Across Electric Heater - °F =  $3160 \times \text{Heater Capacity (kW)} / \text{Airflow (cfm)}$

(a) \* = downflow and horizontal units.

(b) Heaters are rated at 415V. For other than rated voltage, apply the following formula - kW =  $(\text{Required Voltage} / 415)^2 \times \text{Rated kW}$ .

(c) Not all Heater Models are available.

**Table 64. WS\* electric heater voltage correction factors (apply to auxiliary electric heat capacity)**

Nominal Voltage	Distribution Voltage	Capacity Multiplier
200	200	1.00
	380	0.84
415	400	0.93
	415	1.00

**Table 65. WS\* unit wiring**

Unit Model No. (a)	Voltage	MCA	
		Standard Indoor Fan Motor—MCA	Oversized Indoor Fan Motor—MCA
WS*155ED	380–415/50/3	42	46
WS*155ET	200/50/3	84	—
WS*200ED	380–415/50/3	61	64
WS*200ET	200/50/3	12	—

(a) \* = downflow and horizontal units.



**Table 66. WS\* unit wiring with electric heat (single point connection)<sup>(a)</sup>**

Unit Model No. <sup>(b)</sup>	Heater kW Rating	Unit Supply Power	Control Stages	Standard Indoor Motor MCA
WS*155ED	22.6–26.9	380–415/50/3	1	65
	33.8–40.4	380–415/50/3	2	88
	45.1–53.8	380–415/50/3	2	97
WS*155ET	12.5	200/50/3	1	130
	25.0	200/50/3	1	175
	37.5	200/50/3	2	193
WS*200ED	22.6–26.9	380–415/50/3	2	107
	33.8–40.4	380–415/50/3	2	116
	45.1–53.8	380–415/50/3	2	134
WS*200ET	25.0	200/50/3	1	214
	37.5	200/50/3	2	232
	50.0	200/50/3	2	268

(a) All units to be installed under local codes.

(b) \* = downflow and horizontal units.

**Table 67. WS\* electric characteristics—evaporator fan motor—50 cycle**

Unit Model No. <sup>(a)</sup>	Standard Evaporator Motor							Oversized Evaporator Motor						
	No.	Volts	Ph	Watts	FLA	LRA	Service Factor	No.	Volts	Ph	Watts	FLA	LRA	Service Factor
WS*155ED	1	380–415/50/3	3	1500	4.6	36.4	1.15	1	380–415/50/3	3	2200	5.7	57.0	1.5
WS*155ET	1	200/50/3	3	2200	10.8	108	1.5	—	—	—	—	—	—	—
WS*200ED	1	380–415/50/3	3	2200	5.7	57.0	1.5	1	380–415/50/3	3	3700	7.4	71.9	1.15
WS*200ET	1	200/50/3	3	3700	16.6	120	1.15	—	—	—	—	—	—	—

(a) \* = downflow and horizontal units.

**Table 68. WS\* electric characteristics—compressor motor and condenser motor—50 cycle**

Unit Model No. <sup>(a)</sup>	Compressor Motors							Condenser Fan Motors			
	No.	Volts	Ph	Watts	rpm	Amps <sup>(b)</sup>		No.	Ph	Amps <sup>(b)</sup>	
						RLA	LRA			FLA	LRA
WS*155ED	2	380–415/50	3	6400	2900	14	101	2	3	1.4	4.65
WS*155ET	2	200/50	3	6400	2900	28	179	2	3	2.8	9.3
WS*200ED	2	380–415/50	3	8700	2900	19.9	142	2	3	2.2	7.4
WS*200ET	2	200/50	3	8700	2900	43	267	2	3	4.7	15.9

(a) \* = downflow and horizontal units.

(b) For Compressor Motors and Condenser Fan Motors: Amp draw for each motor; multiply value by number of motors to determine total amps.

# Jobsite Connections

**Table 69. Typical number of wires**

Zone Sensors		
<b>A</b>	Manual Changeover	4
	Manual/Auto Changeover	5
	Manual/Auto Changeover with Status Indication LED's	10
	Programmable Night Setback with Status Indication LED's	7
Thermostats		
<b>B</b>	3 Power Wires + 1 Ground Wire (three phase)	

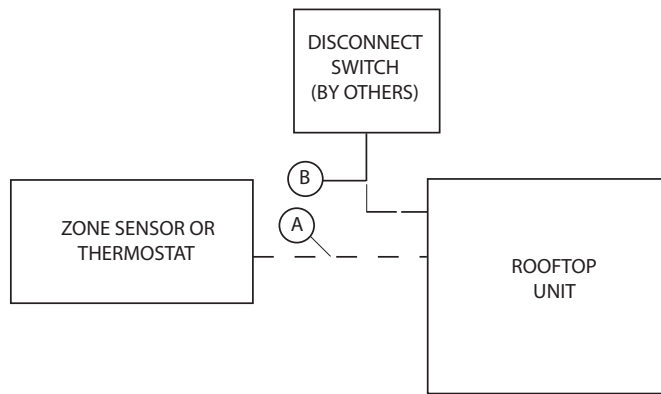

**Notes:**

- For specific wiring information, see the installation instructions.
- All wiring except power wire is low voltage.
- All customer supplied wiring to be copper and must conform to applicable electrical codes (such as NEC or CEC) and local electric codes. Wiring shown dotted is to be furnished and installed by the customer.
- Zone sensor required for units configured for Single Zone VAV indoor fan system control to enable Single Zone VAV functionality.

# Dimensional Data

**Figure 1. Cooling with optional electric heat and gas/electric models—15–25 tons**

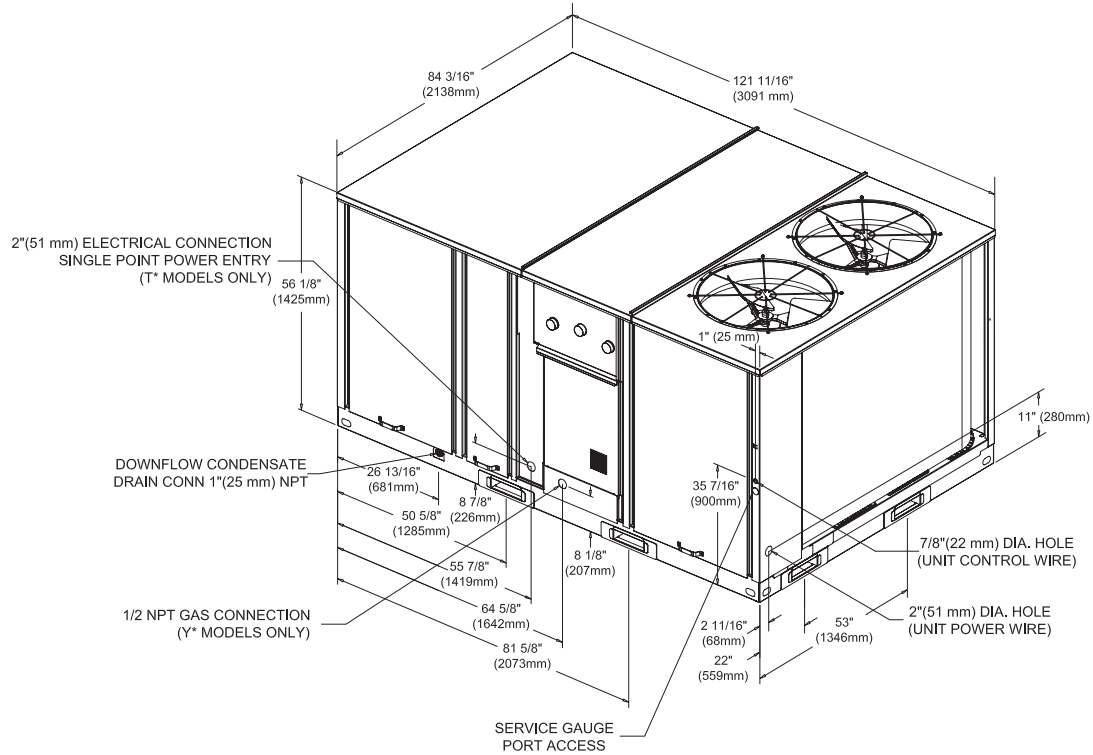

**Figure 2. Cooling with optional electric heat and gas/electric models—15–25 tons & heat pump models 15 and 20 tons —unit clearance and horizontal unit supply/return**

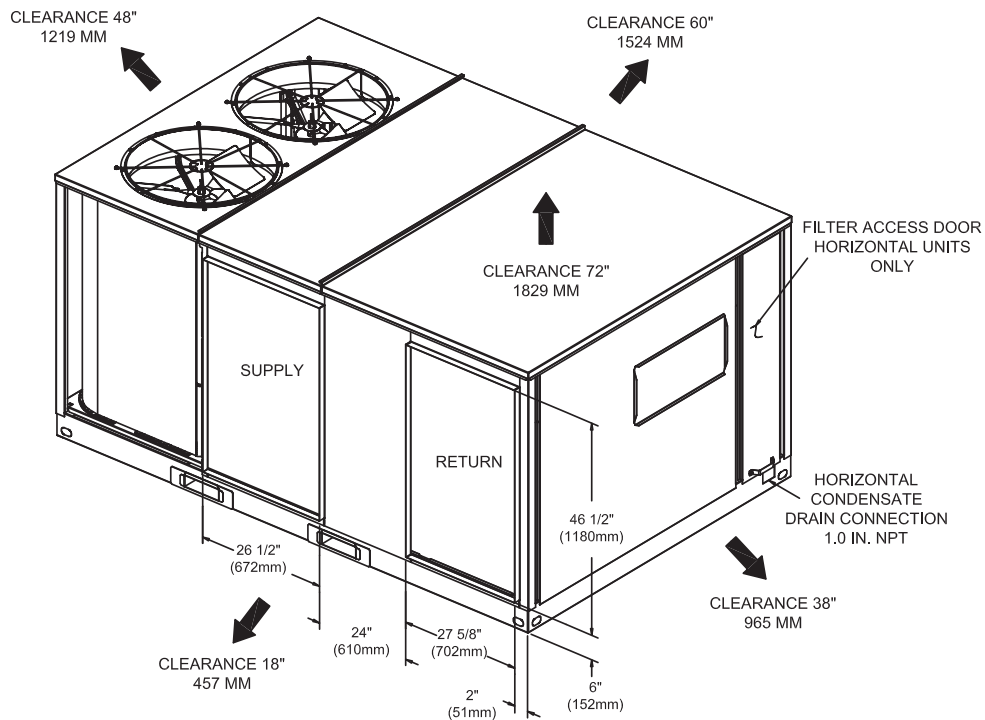



**Figure 5. Cooling and heat pump with optional electric heat and gas/electric models—15–25 tons—roof curb**

\* All dimensions are in inches/millimeters.

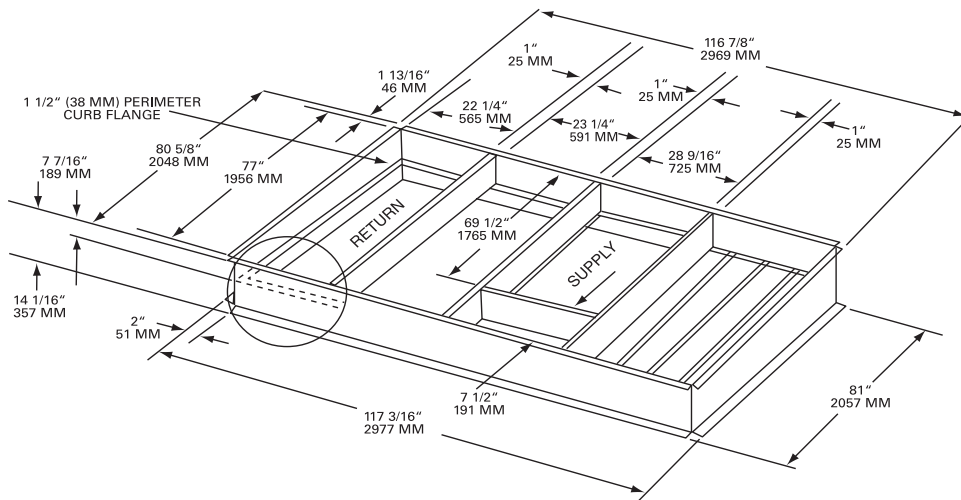

**Figure 6. Cooling and heat pump with optional electric heat and gas/electric models 15–25 tons—downflow duct connections—field fabricated**

\* Duct flanges mount 7-7/16" (189mm) down inside the curb on the 1.5" (38mm) curb flanges. Roofcurb is intended for downflow use only.  
 \* All dimensions are in inches/millimeters.

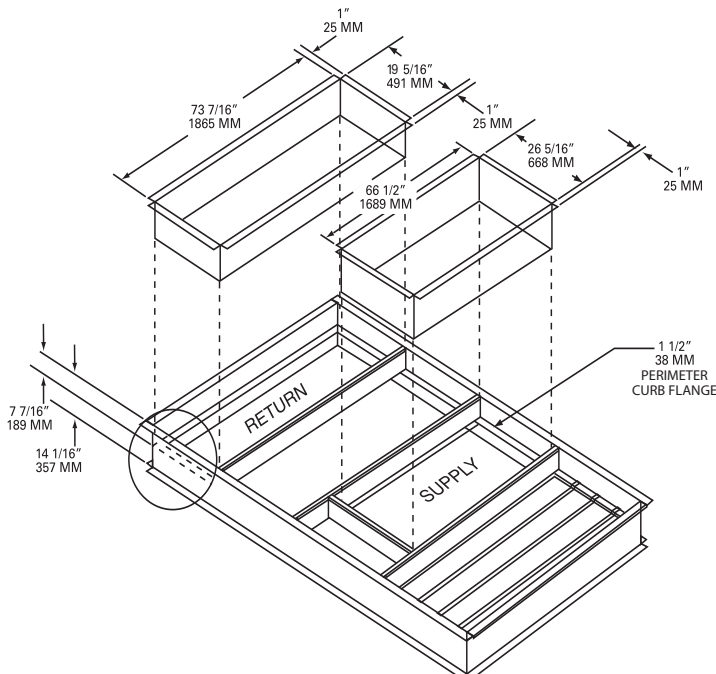

## Dimensional Data

**Figure 7. Cooling and heat pump with optional electric heat and gas/electric models 15–25 tons—downflow unit clearance**

\* All dimensions are in inches/millimeters.

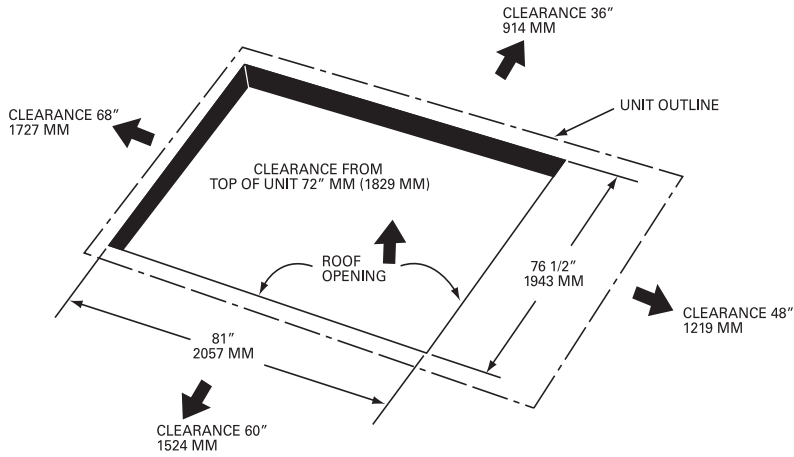

**Figure 8. Downflow & horizontal condensate locations**

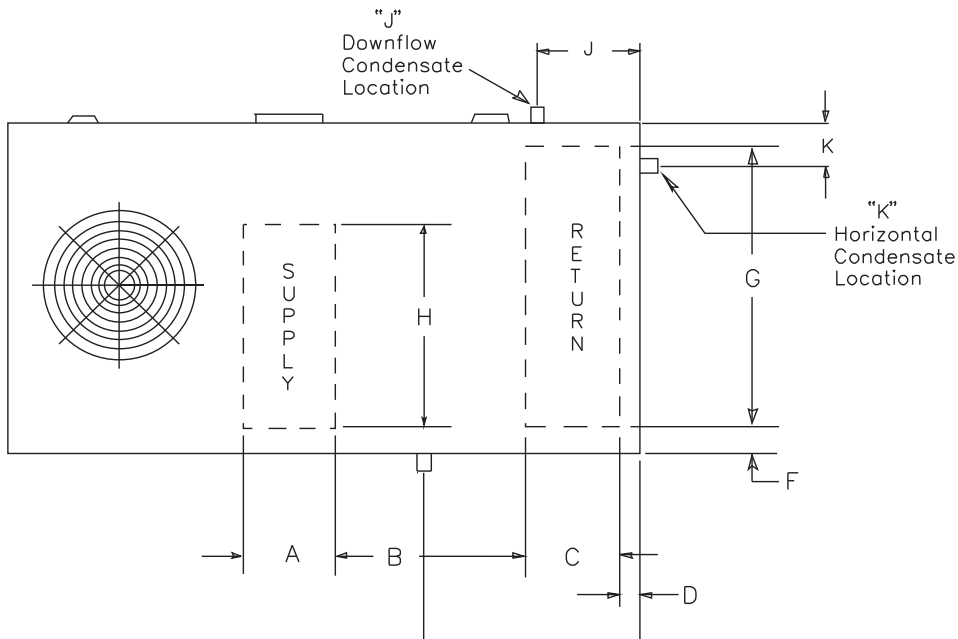

**Table 70. Standard efficiency units (cooling and gas/electric)**

Tons	Downflow Only							Condensate Drain Size	Condensate Drain Location	
	A	B	C	D	F	G	H		Downflow	Horizontal
15-25	26 7/16" 672 mm	28 3/4" 730 mm	19 15/16" 506 mm	4 1/4" 108 mm	4 1/4" 108 mm	76 5/16" 1938 mm	68 11/16" 1745 mm	1 NPT	26 3/4" 679 mm	5 3/8" 137 mm

**Table 71. Cooling unit—swing diameter & through the base electrical**

Unit Model #	A	B	C	D	E
TSD/YSD 155F, 175F, 200F, 250F, WSD155E, 200E	29 1/2	56	38 1/2	18 1/2	N/A

**Note:** \*All dimensions are in inches

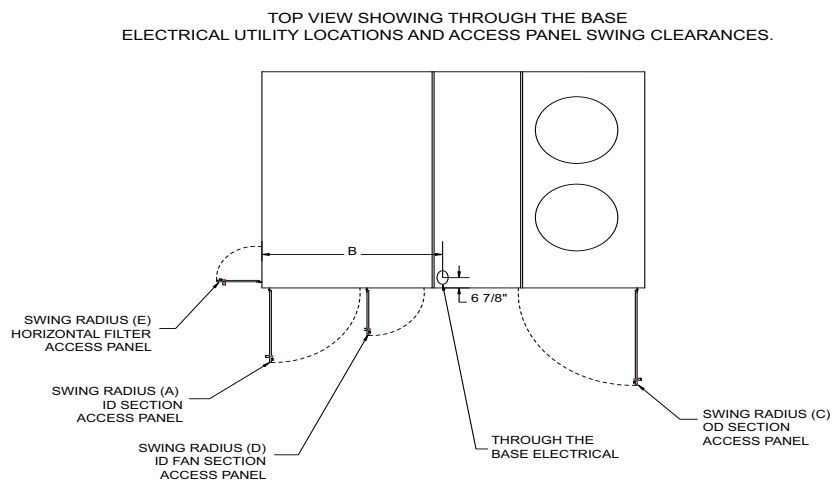

**Figure 9. Fresh air hood (horizontal units)**

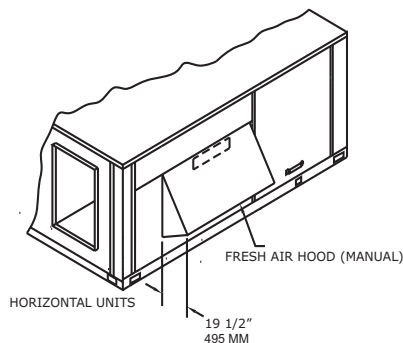

**Figure 10. Fresh air hood (downflow units)**

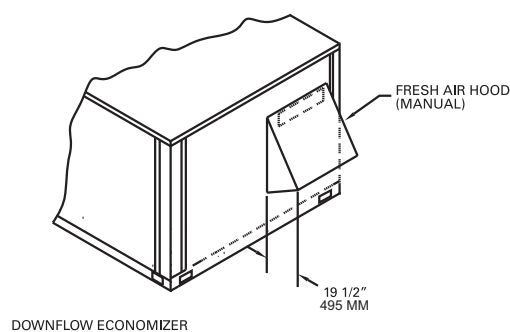

## Dimensional Data

---

**Figure 11. Economizer - horizontal units**

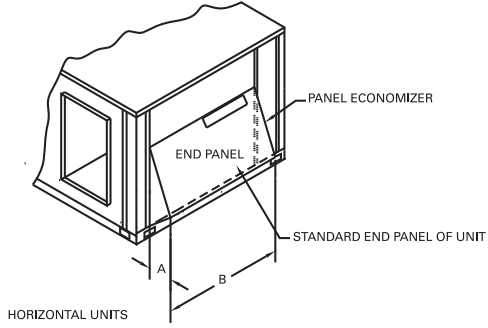

**Note:** When applying economizer to horizontal units, connected ductwork must be run full size to allow proper operation of economizer damper.

**Figure 12. Economizer - downflow units**

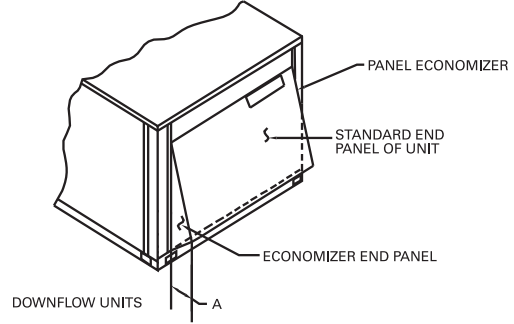



# Weights

**Table 72. TS\* maximum unit and corner weights (kg) and center of gravity dimensions (mm)**

Model	Max Weight (kg)		Corner Weights (kg)				Center of Gravity (mm)	
	Shipping	Net	A	B	C	D	Length	Width
TS*155F	1045	849	275	231	167	177	1448	865
TS*175F	1064	868	275	236	173	182	1459	876
TS*200F	1092	896	285	238	175	198	1424	889
TS*250F	1071	875	277	236	173	189	1447	885

**Notes:**

1. Corner weights are given for information only. All models must be supported continuously by a curb or equivalent frame support.
2. Weights are approximate. Horizontal and downflow unit and corner weights may vary slightly.
3. \*Indicates both horizontal and downflow units.

**Table 73. TS\* maximum unit and corner weights (lb) and center of gravity dimensions (inches)**

Model	Max Weight (lb)		Corner Weights (lb)				Center of Gravity (in)	
	Shipping	Net	A	B	C	D	Length	Width
TS*155F	2299	1868	604	508	367	389	57	34
TS*175F	2340	1909	605	520	381	401	57	34
TS*200F	2402	1971	628	524	384	435	56	35
TS*250F	2355	1924	609	520	381	415	57	35

**Notes:**

1. Corner weights are given for information only. All models must be supported continuously by a curb or equivalent frame support.
2. Weights are approximate. Horizontal and downflow unit and corner weights may vary slightly.
3. \*Indicates both horizontal and downflow units.

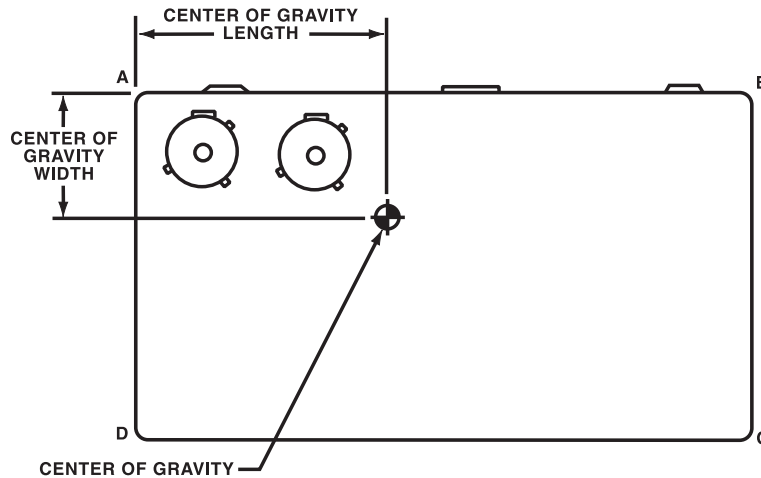



## Weights

### TS\* Accessories

**Table 74. TS\* accessory net weights (kg/lb)<sup>(a), (b), (c)</sup>**

Model	Economizer	Outside Air Damper		Roof Curb	Oversized Motor Adder <sup>(d)</sup>	All Zone Sensors	High Static Drive <sup>(d)</sup>	Low Static Drive <sup>(d)</sup>
	Net	Motorized	Manual					
TSD155F, 175F	—	—	—	—	—	—	—	—
TSD200F	36/79	34/75	15/33	107/236	2/4	0.5/1	1/2	—
TSD250F	36/79	34/75	15/33	107/236	—	0.5/1	—	1/2
TSH155F, 175F	—	—	—	—	—	—	—	—
TSH200F	30/66	34/75	15/33	—	2/4	0.5/1	1/2	—
TSH250F	30/66	34/75	15/33	—	—	0.5/1	—	1/2

(a) Net weight should be added to unit weight when ordering factory installed accessories.

(b) For 600V heaters net weights are same as 480 V heaters.

(c) To estimate shipping weight add 2.3 kg (5 lb) to net weight.

(d) Downflow only.

**Table 75. TS\* accessory net weights (kg)**

Models	Electric Heat				
	5–27 kW	11–14 kW	22–27 kW	22–41 kW	45–54 kW
	380–415 kW	380–415 kW	380–415 kW	380–415 kW	380–415 kW
TS*155F, 175F	—	9.5	12.3	14.5	—
TS*200F	—	—	12.3	14.5	15.4
TS*250F	—	—	12.3	14.5	15.4

**Notes:**

1. Net weight should be added to unit weight when ordering factory installed accessories.
2. For 600 V heaters net weights are same as 480 V heaters.
3. Not available on all models (see Fan Performance tables for specific models).
4. To estimate shipping weight add 5 lb (2.27 kg) to net weight.
5. TS\*155F-250F factory installed options for economizers, multiply net capacity x 0.99, EER x 0.97. For oversized motors, multiply net capacity x 0.98, EER x 0.93.
6. \* Indicates both downflow and horizontal units

**Table 76. TS\* accessory net weights (lb)**

Models	Electric Heat				
	5–27 kW	11–14 kW	22–27 kW	22–41 kW	45–54 kW
	380–415 kW	380–415 kW	380–415 kW	380–415 kW	380–415 kW
TS*155F, 175F	—	21	27	32	—
TS*200F	—	—	27	32	34
TS*250F	—	—	27	32	34

**Notes:**

1. Net weight should be added to unit weight when ordering factory installed accessories.
2. For 600 V heaters net weights are same as 480 V heaters.
3. Not available on all models (see Fan Performance tables for specific models).
4. To estimate shipping weight add 5 lb (2.27 kg) to net weight.
5. TS\*155F-250F factory installed options for economizers, multiply net capacity x 0.99, EER x 0.97. For oversized motors, multiply net capacity x 0.98, EER x 0.93.
6. \* Indicates both downflow and horizontal units

## Weights

### YS\* Unit & Corner Weights, Center of Gravity

**Table 77. YS\* maximum unit and corner weights (kg) and center of gravity dimensions (mm)**

Model	Max Weight		Corner Weights				Center of Gravity	
	Shipping	Net	A	B	C	D	Length	Width
YS*155F	1107	911	292	247	180	190	1450	870
YS*175F	1129	933	296	253	186	197	1454	878
YS*200F	1157	961	306	255	187	213	1420	889
YS*250F	1151	955	304	257	187	207	1438	883

**Notes:**

1. Corner weights are given for information only. All models must be supported continuously by a curb or equivalent frame support.
2. Weights are approximate. Horizontal and downflow unit and corner weights may vary slightly.
3. \*Indicates both horizontal and downflow units.

**Table 78. YS\* maximum unit and corner weights (lb) and center of gravity dimensions (inches)**

Model	Max Weight		Corner Weights				Center of Gravity	
	Shipping	Net	A	B	C	D	Length	Width
YS*155F	2435	2004	642	544	396	419	57	34
YS*175F	2484	2053	651	557	409	434	57	35
YS*200F	2546	2115	673	561	411	468	56	35
YS*250F	2531	2100	669	565	412	455	57	35

**Notes:**

1. Corner weights are given for information only. All models must be supported continuously by a curb or equivalent frame support.
2. Weights are approximate. Horizontal and downflow unit and corner weights may vary slightly.
3. \*Indicates both horizontal and downflow units.

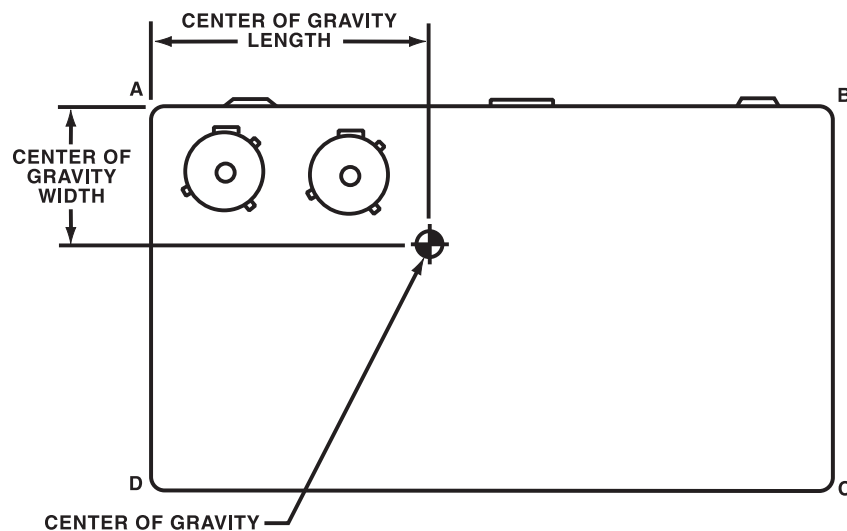



## Weights

### YS\* Accessories

**Table 79. YS\* accessory net weights (kg)<sup>(a), (b)</sup>**

Model	Economizer	Outside Air Damper		Roof Curb <sup>(d)</sup>	Oversized Motor Adder <sup>(c)</sup>	LPG Conversion Kit	All Zone Sensors	High Static Drive <sup>(c)</sup>	Low Static Drive <sup>(c)</sup>
	Net	Motorized	Manual						
YSD155F, 175F	—	—	—	—	—	—	—	—	—
YSD200F	36	34	15	107	2	2	0.5	1	—
YSD250F	36	34	15	107	—	2	0.5	—	1
YSH155F, 175F	—	—	—	—	—	—	—	—	—
YSH200F	30	34	15	—	2	2	0.5	1	—
YSH250F	30	34	15	—	—	2	0.5	—	1

(a) Net weight should be added to unit weight when ordering factory installed accessories.

(b) Not available on all models. (See fan performance table for specific models).

(c) YS\* 155F-250F factory installed options for economizers, multiply net capacity x 0.99, EER x 0.97. For oversize motors, multiply net capacity x 0.98, EER x 0.93.

(d) Downflow only.

**Table 80. YS\* accessory net weights (lb)<sup>(a), (b)</sup>**

Model No	Economizer	Outside Air Damper		Roof Curb <sup>(c)</sup>	Oversized Motor Adder <sup>(d)</sup>	LPG Conversion Kit	All Zone Sensors	High Static Drive <sup>(d)</sup>	Low Static Drive <sup>(d)</sup>
	Net	Motorized	Manual						
YSD155F, 175F	—	—	—	—	—	—	—	—	—
YSD200F	79	75	33	236	4	4	1	2	—
YSD250F	79	75	33	236	—	4	1	—	2
YSH155F, 175F	—	—	—	—	—	—	—	—	—
YSH200F	66	75	33	—	4	4	1	2	—
YSH250F	66	75	33	—	—	4	1	—	2

(a) Net weight should be added to unit weight when ordering factory installed accessories.

(b) Not available on all models. (See fan performance table for specific models).

(c) Downflow only.

(d) YS\* 155F-250F factory installed options for economizers, multiply net capacity x 0.99, EER x 0.97. For oversize motors, multiply net capacity x 0.98, EER x 0.93.

## Weights

### WS\* Unit & Corner Weights, Center of Gravity

**Table 81. WS\* maximum unit and corner weights (kg) and center of gravity dimensions (mm)**

Model	Max Weight		Corner Weights				Center of Gravity	
	Shipping	Net	A	B	C	D	Length	Width
WS*155E	1118	922	295	239	176	213	1388	902
WS*200E	1201	999	326	262	183	228	1376	881

**Notes:**

1. Corner weights are given for information only. All models must be supported continuously by a curb or equivalent frame support.
2. \*Indicates both horizontal and downflow units.

**Table 82. WS\* maximum unit and corner weights (lb) and center of gravity dimensions (inches)**

Model	Max Weight		Corner Weights				Center of Gravity	
	Shipping	Net	A	B	C	D	Length	Width
WS*155E	2459	2028	648	525	386	469	55	35
WS*200E	2641	2198	717	575	403	502	54	35

**Notes:**

1. Corner weights are given for information only. All models must be supported continuously by a curb or equivalent frame support.
2. \*Indicates both horizontal and downflow units.

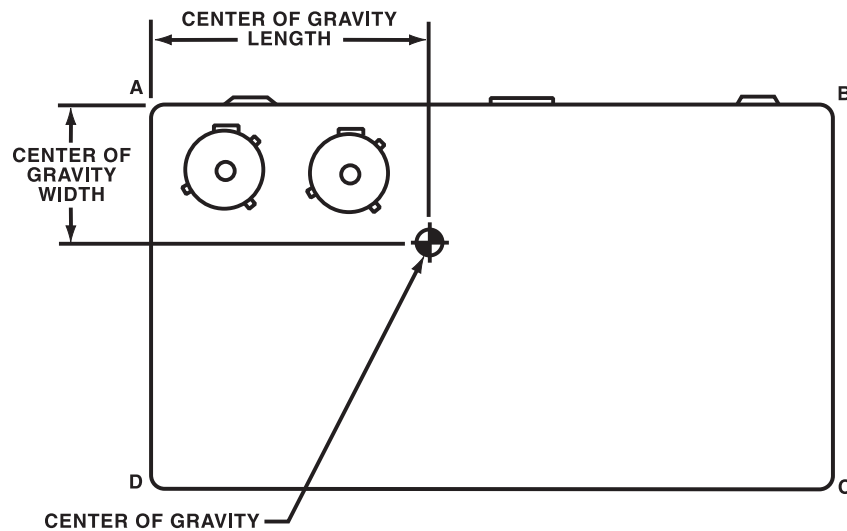



## Weights

### WS\* Accessories

**Table 83. WS\* accessory net weights (kg)<sup>(a), (b), (c), (d)</sup>**

Model	Economizer <sup>(e)</sup>	Outside Air Damper		Roof Curb	Oversized Motor Adder <sup>(e)</sup>	All Zone Sensors	High Static Drive <sup>(f)</sup>	Low Static Drive <sup>(f)</sup>
	Net	Motorized	Manual					
WSD155E	—	—	—	—	—	—	—	—
WSD200E	36	34	15	107	2	0.5	5	—
WSH155E	—	—	—	—	—	—	—	—
WSH200E	30	34	15	—	—	0.5	7	—

- (a) To estimate shipping weight add 2.3 kg to net weight.  
 (b) Downflow only.  
 (c) Not available on all models (see fan performance tables for specific models).  
 (d) D = Downflow unit, H = Horizontal unit.  
 (e) Net weight should be added to unit weight when ordering factory installed accessories.  
 (f) Multiply by 1.25 for net weight of 200–230 V rated heaters.

**Table 84. WS\* accessory net weights (lb)<sup>(a), (b), (c), (d)</sup>**

Model	Economizer <sup>(e)</sup>	Outside Air Damper		Roof Curb	Oversized Motor Adder <sup>(e)</sup>	All Zone Sensors	High Static Drive <sup>(f)</sup>	Low Static Drive <sup>(f)</sup>
	Net	Motorized	Manual					
WSD155E	—	—	—	—	—	—	—	—
WSD200E	79	75	33	236	4	1	11	—
WSH155E	—	—	—	—	—	—	—	—
WSH200E	66	75	33	—	—	1	15	—

- (a) To estimate shipping weight add 2.3 kg to net weight.  
 (b) Downflow only.  
 (c) Not available on all models (see fan performance tables for specific models).  
 (d) D = Downflow unit, H = Horizontal unit.  
 (e) Net weight should be added to unit weight when ordering factory installed accessories.  
 (f) Multiply by 1.25 for net weight of 200–230 V rated heaters.

**Table 85. WS\* accessory net weights (kg)**

Models	Electric Heat				
	5–27 kW	11–14 kW	22–27 kW	22–41 kW	45–54 kW
	380–415 kW	380–415 kW	380–415 kW	380–415 kW	380–415 kW
WS*155E	—	9.5	12.3	14.5	—
WS*200E	—	—	12.3	14.5	15.4

- Notes:**  
 1. Net weight should be added to unit weight when ordering factory installed economizer or oversize motor.  
 2. Not available on all models (see Fan Performance tables for specific models).  
 3. To estimate shipping weight add 2.3 kg to net weight.  
 4. Downflow only.  
 5. \* Indicates both downflow and horizontal units

**Table 86. WS\* accessory net weights (lb)**

Models	Electric Heat				
	5–27 kW	11–14 kW	22–27 kW	22–41 kW	45–54 kW
	380–415 kW	380–415 kW	380–415 kW	380–415 kW	380–415 kW
WS*155E	—	21	27	32	—
WS*200E	—	—	27	32	34

- Notes:**  
 1. Net weight should be added to unit weight when ordering factory installed economizer or oversize motor.  
 2. Not available on all models (see Fan Performance tables for specific models).  
 3. To estimate shipping weight add 5 lb to net weight.  
 4. Downflow only.  
 5. \* Indicates both downflow and horizontal units

# Mechanical Specifications

## General

The units shall be dedicated downflow or horizontal airflow. The operating range shall be between 115°F and 0°F in cooling as standard from the factory for all units. Cooling performance shall be rated in accordance with ARI testing procedures. All units shall be factory assembled, internally wired, fully charged with R-410A, and 100 percent run tested to check cooling operation, fan and blower rotation and control sequence, before leaving the factory. Wiring internal to the unit shall be colored and numbered for simplified identification.

## Casing

Unit casing shall be constructed of zinc coated, heavy gauge, galvanized steel. Exterior surfaces shall be cleaned, phosphatized, and finished with a weather-resistant baked enamel finish. Unit's surface shall be tested 500 hours in a salt spray test in compliance with ASTM B117. Cabinet construction shall allow for all maintenance on one side of the unit. In order to ensure a water and air tight seal, service panels shall have lifting handles and no more than three screws to remove. All exposed vertical panels and top covers in the indoor air section shall be insulated with a 1/2-inch, 1-pound density foil-faced, fire-resistant, permanent, odorless, glass fiber material. The base of the downflow unit shall be insulated with 1/2-inch, 1-pound density foil-faced, closed-cell material. The downflow unit's base pan shall have no penetrations within the perimeter of the curb other than the raised 11/8-inch high supply/return openings to provide an added water integrity precaution, if the condensate drain backs up. The base of the unit shall have provisions for forklift and crane lifting.

## Discharge Line Thermostat

A bi-metal element discharge line thermostats installed as a standard option on the discharge line of each system. This standard option provides extra protection to the compressors against high discharge temperatures in case of loss of charge, extremely high ambient and other conditions which could drive the discharge temperature higher. Discharge line thermostat is wired in series with high pressure control. When the discharge temperature raises high above the protection limit, the bi-metal disc in the thermostat switches to off position to open the 24 Vac circuit. When the temperature on discharge line cools down, the bi-metal disc closes the contactor circuit to provide power to compressor. When the thermostat opens the fourth time, the ReliaTel™ control must be manually reset to resume operation on that stage.

## Unit Top

The top cover shall be one piece, or where seams exist, double hemmed and gasket sealed to prevent water leakage.

## Filters

Two inch standard filters shall be factory supplied on all units. Optional 2-inch MERV 8 and MERV 13 filters with a filter removal too shall also be available.

## Compressors

All units shall have direct-drive, hermetic, scroll type compressors with centrifugal type oil pumps. Motor shall be suction gas-cooled and shall have a voltage utilization range of plus or minus 10 percent of nameplate voltage. Internal overloads shall be provided with the scroll compressors. All models shall have crankcase heaters, low and high pressure control as standard.

## Crankcase Heaters

These band heaters provide improved compressor reliability by warming the oil to prevent migration during off-cycles or low ambient conditions. These are standard on all Voyager™ models.

## Mechanical Specifications

---

### Refrigerant Circuits

Each refrigerant circuit shall have independent fixed orifice or thermostatic expansion devices, service pressure ports, and refrigerant line filter driers factory installed as standard. An area shall be provided for replacement suction line driers.

### Evaporator and Condenser Coils

Internally finned, 5/16" copper tubes mechanically bonded to a configured aluminum plate fin shall be standard for evaporator coils. Condenser coils may also be microchannel type (major design sequence F units only). Coils shall be leak tested at the factory to ensure the pressure integrity. The evaporator coil and condenser coil shall be leak tested to 225 psig and pressure tested to 450 psig. All dual compressor units shall have intermingled evaporator coils. Sloped condensate drain pans are standard. Round tube plate fin type condenser coils are patent-pending 1+1+1 coils, permanently gapped for easy cleaning.

### Gas Heating Section

The heating section shall have a drum and tube heat exchanger design using corrosion resistant steel components. A forced combustion blower shall supply premixed fuel to a single burner ignited by a pilotless hot surface ignition system. In order to provide reliable operation, a negative pressure gas valve shall be used that requires blower operation to initiate gas flow. On an initial call for heat, the combustion blower shall purge the heat exchanger 45 seconds before ignition. After three unsuccessful ignition attempts, the entire heating system shall be locked out until manually reset at the thermostat. Units shall be suitable for use with natural gas or propane (field installed kit) and shall also comply with California requirements for low NO<sub>x</sub> emissions. The 15–25 tons shall have two stage heating (Gas/Electric Only).

### Outdoor Fans

The outdoor fan shall be direct-drive, statically and dynamically balanced, draw-through in the vertical discharge position. The fan motor(s) shall be permanently lubricated and shall have built-in thermal overload protection.

### Indoor Fan

Units above shall have belt driven, FC centrifugal fans with adjustable motor sheaves. Units with standard motors shall have an adjustable idler-arm assembly for quick-adjustment of fan belts and motor sheaves. All motors shall be thermally protected. Oversized motors shall be available for high static application. All indoor fan motors meet the U.S. Energy Policy Act of 1992 (EPACT).

### Controls

Unit shall be completely factory wired with necessary controls and contactor pressure lugs or terminal block for power wiring. Unit shall provide an external location for mounting a fused disconnect device. ReliaTel controls shall be provided for all 24-volt control functions. The resident control algorithms shall make all heating, cooling, and/or ventilating decisions in response to electronic signals from sensors measuring indoor and outdoor temperatures. The control algorithm maintains accurate temperature control, minimizes drift from set point, and provides better building comfort. A centralized control shall provide anti-short cycle timing and time delay between compressors to provide a higher level of machine protection.

### Defrost Controls

Adaptive demand defrost shall be provided to permit defrost wherever coil icing conditions begin to significantly reduce unit capacity.



## Factory Installed Options

### **Black Epoxy Coated Pre-Coated Coils**

The black epoxy coils have a thermoset vinyl coating that is bonded to the aluminum fin stock prior to the fin-stamping process. The pre-coated coils are an economical option for protection in mildly corrosive environments.

### **CO<sub>2</sub> Sensor Wiring**

The unit wiring for field installed CO<sub>2</sub> sensors. Factory-installed CO<sub>2</sub> sensor wiring saves time and ensures proper unit connections for the field installed CO<sub>2</sub> sensor kits.

### **Complete Coat™ Microchannel Condenser Coil**

The cathodic epoxy type electrodisposition coating is formulated for high edge build to a number of different types of heat exchangers. The coating is selected to provide excellent resistance and durability to corrosive effects of alkalis, acids, alcohols, petroleum, seawater, salty air and other corrosive environments. This coating shall be available on microchannel condenser coils.

### **Condensate Overflow Switch**

This option shall shut the unit down in the event that a clogged condensate drain line prevents proper condensate removal from the unit.

### **Hinged Access Doors**

Sheet metal hinges are available on the Filter, Evaporator, Fan/Motor and the Compressor/Control Access Doors. This option is available on all models.

### **Stainless Steel Drain Pan**

This option provides excellent corrosion and oxidation resistance. Drain pan shall be reversible and constructed of 304 stainless steel.

### **Stainless Steel Heat Exchanger**

Gas heat exchanger shall be of drum and tube design constructed from a minimum 304 Grade stainless steel. The stainless steel heat exchanger shall have a 10-year warranty as standard (Gas/Electric Only).

### **Through the Base Electrical with Circuit Breaker**

This option is a thermal magnetic, molded case, HACR Circuit Breaker with provisions for through the base electrical connections. The circuit breaker will be installed in a water tight enclosure in the unit with access through a swinging door. Factory wiring will be provided from the switch to the unit high voltage terminal block. The circuit breaker will provide overcurrent protection, be sized per NEC and UL guidelines, and be agency recognized by UL/CSA. This option is available on all downflow models.

### **Through the Base Electrical With Disconnect Switch**

Three-pole, molded case, disconnect switch with provisions for through the base electrical connections are available. The disconnect switch will be installed in the unit in a water tight enclosure with access through a swinging door. Factory wiring will be provided from the switch to the unit high voltage terminal block. The switch will be UL/CSA agency recognized.

**Note:** *The disconnect switch will be sized per NEC and UL guidelines but will not be used in place of unit overcurrent protection. This option is available on all downflow models.*

### **Through the Base Utilities Access**

An electrical service entrance shall be provided allowing electrical access for both control and main power connections inside the curb and through the base of the unit. Option will allow for field installation of liquid-tight conduit and an external field installed disconnect switch.

## Mechanical Specifications

---

### Two-Inch Pleated Filters

Two-inch MERV 8 and MERV 13 media filters with filter removal tool shall be available on all models.

## Factory or Field Installed Options

### Clogged Filter/Fan Failure Switch

A dedicated differential pressure switch is available to achieve active fan failure indication and/or clogged filter indication. These indications will be registered with either a zone sensor with status indication lights or an Integrated Comfort™ System.

These options allow for individual fan failure and dirty filter indication. The fan failure switch will disable all unit functions and “flash” the Service LED on the zone sensor. The dirty filter switch will light the Service LED on the zone sensor and will allow continued unit operation.

### Discharge Air Sensing Kit

This kit provides true discharge air sensing in heating models. This sensor is a status indicator readable through Tracer™ or Tracker™. The kit is functional only with the ReliaTel™ Options Module.

### Economizer—Downflow

The assembly includes fully modulating 0–100 percent motor and dampers, barometric relief, minimum position setting, preset linkage, wiring harness with plug, fixed dry bulb and spring return actuator. The barometric relief damper shall be standard with the downflow economizer and shall provide a pressure operated damper that shall be gravity closing and shall prohibit entrance of outside air during the equipment “off” cycle. Solid state enthalpy and differential enthalpy control shall be field-installed.

### Electric Heaters

Electric heat modules shall be available for installation within the basic unit. Electric heater elements shall be constructed of heavy-duty nickel chromium elements internally delta connected for 240 volt, wye connected for 480 and 600 volt. Staging shall be achieved through ReliaTel. Each heater package shall have automatically reset high limit control operating through heating element contactors. All heaters shall be individually fused from the factory, where required, and shall meet all NEC and CEC requirements when properly installed. Power assemblies shall provide single-point connection. Electric heat modules shall be UL listed or CSA certified. If ordering the Through the Base Electrical option with an Electric Heater, the heater must be factory installed.

### Frostat™

This option is to be utilized as a safety device. The Frostat opens when temperatures on the evaporator coil fall below 10°F. The temperature will need to rise to 50°F before closing. This option should be utilized in low airflow or high outside air applications.

### LonTalk® Communications Interface

The LonTalk communications interface, when installed in a Voyager unit, allows the unit to communicate as a Tracer LCI-V device or directly with generic LonTalk Network Building Automation System Controls.

### Trane Communication Interface

This factory or field-installed option shall be provided to interface ReliaTel controlled units with the Trane Integrated Comfort systems.

## Field Installed Options

### **Barometric Relief**

Designed to be used on downflow units, barometric relief is an unpowered means of relieving excess building pressure.

### **CO<sub>2</sub> Sensor**

The CO<sub>2</sub> sensor shall have the ability to monitor the concentration (parts per million, ppm) of CO<sub>2</sub> (Carbon Dioxide) in the air. As the CO<sub>2</sub> concentration changes, the outside air damper modulates to meet the current ventilation needs of the zone.

**Note:** Choose factory-installed CO<sub>2</sub> sensor wiring option to save time and ensure proper unit connections for the field installed CO<sub>2</sub> sensor kits.

### **Digital Display Zone Sensor**

The Digital LCD (Liquid Crystal Display) zone sensor has the look and functionality of standard zone sensors. This sensor includes a digital display of set point adjustment and space temperature in F (Fahrenheit) or C (Celsius). Includes FAN and SYSTEM buttons (supports the service functions of the standard sensor). E-squared memory stores last programmed set points. Requires 24 Vac (Volts AC). This sensor should be utilized with ReliaTel™ controls.

### **Economizer—Horizontal**

The horizontal economizer shall contain the same features as the downflow economizer with the exception of barometric relief.

### **High Static Drive**

The high static drive option shall allow the standard motor on the 15-, 20-, and 25-ton units to operate with improved external static capabilities.

### **Low Static Drive**

The low static drive option shall allow the standard motor on the 17½- and 20-ton to operate at low static conditions.

### **Manual Outside Air Damper**

The rain hood and screen shall provide up to 25 percent outside air.

### **Motorized Outside Air Dampers**

Manually set outdoor air dampers shall provide up to 50 percent outside air. Once set, outdoor air dampers shall open to set position when indoor fan starts. The damper shall close to the full closed position when indoor fan shuts down.

### **Reference or Comparative Enthalpy**

Reference Enthalpy is used to measure and communicate outdoor humidity. The unit receives and uses this information to provide improved comfort cooling while using the economizer.

Comparative Enthalpy measures and communicates humidity for both outdoor and return air conditions, and return air temperature. The unit receives and uses this information to maximize use of economizer cooling, and to provide maximum occupant comfort control. Reference or Comparative Enthalpy option shall be available when a field installed Downflow Economizer is ordered. This option is available on all models.

The powered exhaust shall provide exhaust of return air, when using an economizer, to maintain better building pressurization.

## **Mechanical Specifications**

---

### **Roof Curb—Downflow**

The roof curb shall be designed to mate with the downflow unit and provide support and a water tight installation when installed properly. The roof curb design shall allow field-fabricated rectangular supply/return ductwork to be connected directly to the curb. Curb design shall comply with NRCA requirements. Curb shall be shipped knocked down for field assembly and shall include wood nailer strips.

### **Economizer—Horizontal**

The horizontal economizer shall contain the same features as the downflow economizer with the exception of barometric relief.

### **Oversized Motors**

Oversized motors shall be available for high static applications.

### **Remote Potentiometer**

The minimum position setting of the economizer shall be adjusted with this accessory.

### **Tool-less Hail Guards**

Tool-less, hail protection quality coil guards are available for condenser coil protection.

### **Ventilation Override Accessory**

With the Ventilation Override Accessory installed, the unit can be set to transition up to three different pre-programmed sequences for Smoke Purge, Pressurization, and Exhaust. The transition occurs when a binary input on the RTOM is closed (shorted). This would typically be a hard wired relay output from a smoke detector or fire control panel.

### **Zone Sensors**

This option shall be provided to interface with the Micro equipped Voyagers and shall be available in either manual, automatic, programmable with night setback, with system malfunction lights or remote sensor options.





Ingersoll Rand (NYSE:IR) advances the quality of life by creating comfortable, sustainable and efficient environments. Our people and our family of brands—including Club Car®, Ingersoll Rand®, Thermo King® and Trane®—work together to enhance the quality and comfort of air in homes and buildings; transport and protect food and perishables; and increase industrial productivity and efficiency. We are a global business committed to a world of sustainable progress and enduring results.



[ingersollrand.com](http://ingersollrand.com)

Ingersoll Rand has a policy of continuous product and product data improvement and reserves the right to change design and specifications without notice.  
We are committed to using environmentally conscious print practices.